

ABB MEASUREMENT & ANALYTICS | DATA SHEET

# TZIDC

## Digital positioner



---

For highly accurate and reliable positioning of valves in all sectors

---

### **Easy Set-up**

- Automatic adjustment function
- Straightforward initialization

---

### **Wide temperature range**

- -40 to 85 °C (-40 to 185 °F)

---

### **HART Communication**

---

### **Control Adaptive function**

- Automatic adjustment of control parameters during operation

---

### **Increased shock and vibration resistance**

- Gearless sensor activation

---

### **Fail Save and Fail Freeze function**

- Selectable safety position of the fitting

---

### **Low air consumption**

- Highly efficient I/P converter

---

## Brief description

The TZIDC is an electronically configurable positioner with communication capabilities designed for mounting on pneumatic linear or rotary actuators. It features a small and compact design, a modular construction, and an excellent cost-performance ratio.

Fully automatic determination of the control parameters and adaptation to the positioner allow for considerable time savings as well as optimum control behavior.

### Pneumatics

An I/P module with subsequent pneumatic amplifier is used to control the pneumatic actuator. The well-proven I/P module proportionally converts the permanent electrical setpoint signal from the CPU into a pneumatic signal used to adjust a 3/3-way valve.

Dosing of the air flow for pressurizing or depressurizing the actuator is continuously adjusted. As a result, excellent control results are achieved. When reaching the setpoint, the 3/3-way valve is closed in center position to minimize the air consumption.

The pneumatic system can be supplied in four versions: for single acting and double acting actuators and each with the 'fail-safe' / 'fail-freeze' safety function.

#### 'Fail-safe' safety function

If the electric power supply fails, the positioner output 1 is depressurized and the return spring in the pneumatic actuator moves the valve to the safe position. In case of a 'double-acting' version, output 2 is additionally pressurized.

#### 'Fail-freeze' function

If the electric power supply fails, the positioner Output 1 (and Output 2 if applicable) is closed and the pneumatic actuator blocks the valve in the current position. If the compressed air supply power fails, the positioner depressurizes the actuator.

### Use

The positioner has a built-in operating panel providing a 2-line LCD indicator and 4 operating buttons for commissioning, configuration and monitoring during live operation.

Alternatively, the appropriate configuration program can be used via the available communication interface.

### Communication

The positioner has a local communication interface (LCI) as standard. Additionally, a 'HART® communication' option for communication via the 20 mA signal is available. Both communications are based on the HART® Protocol.

Alternatively, HART®5 or HART®7 are available.

### Inputs / Outputs

In addition to its input for the analog position setpoint, the positioner is equipped with a digital input which can be used to activate control system functions in the device. A digital output allows you to output collective messages (alarms / faults).

### Modular design

The basic model can be enhanced at any time by retrofitting optional equipment.

Option modules can be installed for analog and digital position feedback.

Additionally, a mechanical position indicator, proximity switches or 24 V microswitches are available for indicating the position independently of the mother board function.

## ... Brief description

### Schematic diagram

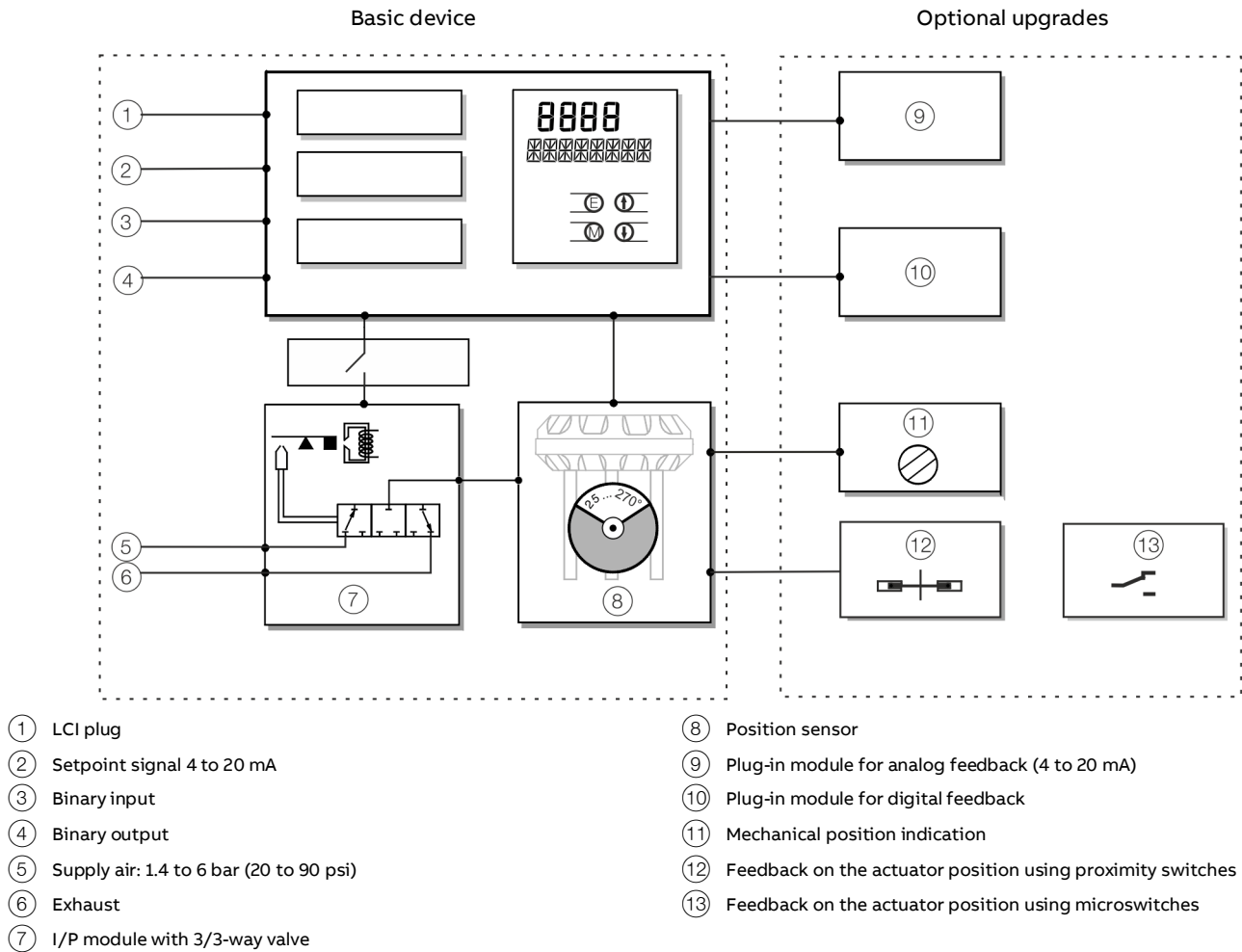

- ① LCI plug
- ② Setpoint signal 4 to 20 mA
- ③ Binary input
- ④ Binary output
- ⑤ Supply air: 1.4 to 6 bar (20 to 90 psi)
- ⑥ Exhaust
- ⑦ I/P module with 3/3-way valve
- ⑧ Position sensor
- ⑨ Plug-in module for analog feedback (4 to 20 mA)
- ⑩ Plug-in module for digital feedback
- ⑪ Mechanical position indication
- ⑫ Feedback on the actuator position using proximity switches
- ⑬ Feedback on the actuator position using microswitches

Figure 1: Schematic diagram of the positioner

#### Note

With optional extensions, either the 'Feedback on the actuator position using proximity switches' (12) or the 'Feedback on the actuator position using microswitches' (13) can be used. The mechanical position indication (11) must be installed in both cases.

## Mounting versions

### Standardized mounting on pneumatic linear actuators

Lateral attachment is in accordance with DIN / IEC 534 (lateral attachment to NAMUR). The required attachment kit is a complete set of attachment material, but does not include the pipe fittings and air pipes.

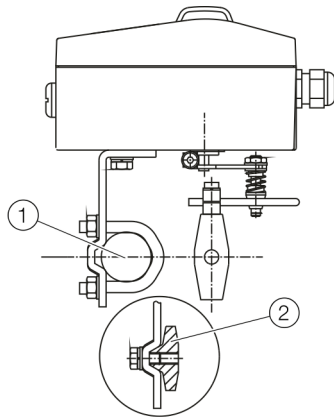

① Columnar yoke      ② Cast iron yoke

Figure 2: Mounting on linear actuators in accordance with DIN / IEC 534

### Standardized mounting on pneumatic rotary actuators

This attachment is designed for mounting according to the standard VDI / VDE 3845. The attachment kit consists of a console with mounting screws for mounting on a rotary actuator. The corresponding feedback shaft adapter has to be ordered separately. Screwed pipe connections and air pipes have to be provided on site.

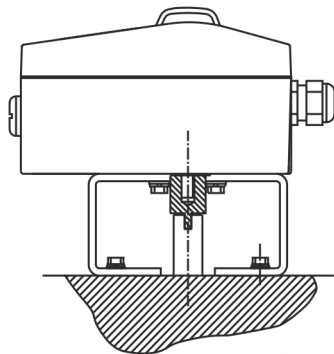

Figure 3: Mounting on rotary actuators in accordance with VDI / VDE 3845

### Integral mounting to control valves

The positioner featuring standard pneumatic action is available as an option for integral mounting. The required holes are found at the back of the device. The advantage of integrated mounting is that the point for mechanical stroke measurement is protected and that the positioner and actuator are linked internally. No external tubing is required.

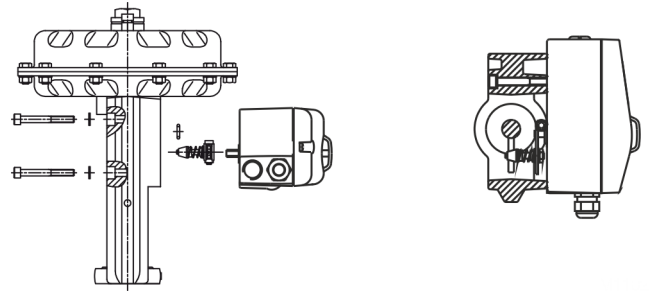

Figure 4: Integral mounting on control valves

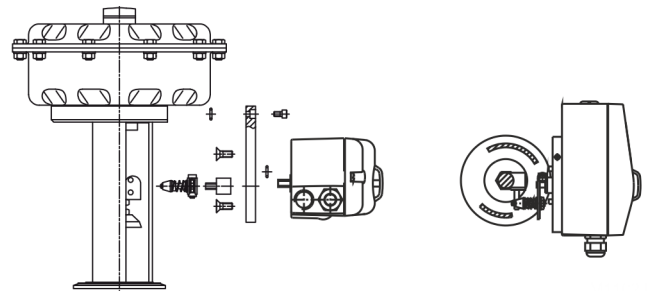

Figure 5: Integral mounting on control valves with adapter plate

### Special actuator-specific mounting versions

In addition to the mounting methods described above, there are special actuator-specific attachments.

## ... Mounting versions

### External position sensors

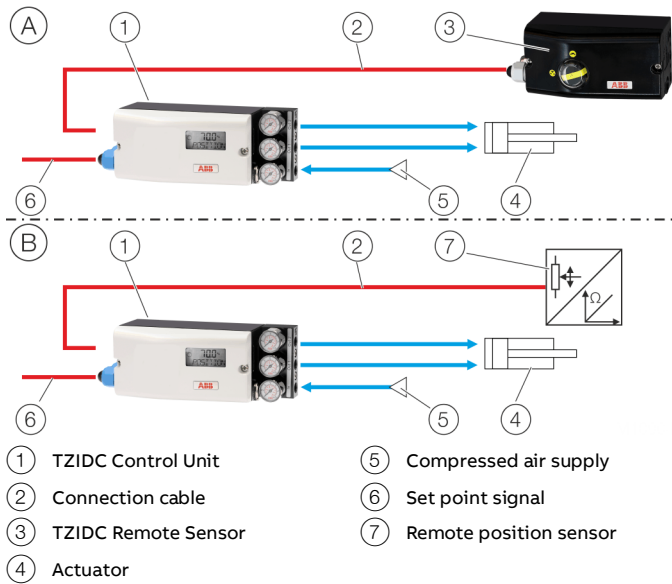

Figure 6: TZIDC with external position sensors

#### Note

If the device is being operated on a cylinder, for reasons associated with linearity you should run the Auto Adjust function for rotary actuators

#### Ⓐ TZIDC Control Unit with TZIDC Remote Sensor\*

In this version, the components are supplied in two housings, which together form one harmonized unit.

The following points should be observed during installation:

- Housing 1 (TZIDC Control Unit) contains the electronics and pneumatics and is mounted separately from the actuator.
- Housing 2 (TZIDC Remote Sensor) contains the position sensor and is mounted on the linear and rotary actuator.

\* The TZIDC Remote Version is temporarily not available for the marine version.

#### Note

To connect the TZIDC Remote Sensor, a cable with the following specifications needs to be used:

- 3-wire, cross-section 0.5 to 1.0 mm<sup>2</sup>
- shielded, with at least 85 % coverage
- Temperature range up to at least 100 °C (212 °F)

The cable glands must also be approved for a temperature range up to at least 100 °C (212 °F). The cable glands require a mounting for the shielding and strain relief for the cable in addition.

#### Ⓑ TZIDC Control Unit for remote position sensor

In this version the positioner is supplied without a position sensor.

The following points should be observed during installation:

- Housing 1 (TZIDC Control Unit) contains the electronics and pneumatics and is mounted separately from the actuator.
- The remote position sensor is mounted on the linear and rotary actuator. Follow the operating instructions for the remote position sensor for mechanical mounting!

## Device parameters

### General

Microprocessor-based position control in the positioner optimizes control. The positioner features high-precision control functions and high operational reliability. Due to their elaborate structure and easy accessibility, the device parameters can be quickly adapted to the respective application.

The total range of parameters includes:

- Operating parameters
- Adjustment parameters
- Operation monitoring parameters
- Diagnosis parameters
- Maintenance parameters

### Operating parameters

The following operating parameters can be set manually if required:

#### Setpoint signal

0 to 100 % freely selectable for split-range operation

For 4 to 20 mA and HART version:

- Signal min. 4 mA, max. 20 mA (0 to 100 %)
- Minimum range 20 % (3.2 mA)
- Recommended range > 50 % (8.0 mA)

Action (set point signal)

Increasing:

- Position value 0 to 100 % = direction 0 to 100 %

Decreasing:

- Setpoint signal 100 to 0 % = direction 0 to 100 %

Characteristic curve (actuator travel = f {set point signal})  
Linear, equal percentage 1:25 or 1:50 or 25:1 or 50:1 or freely configurable with 20 reference points.

#### Actuator travel limit

The actuator travel, i.e. the stroke or angle of rotation, can be reduced as needed within the full range of 0 to 100 %, provided that a minimum value of 20 % is observed.

#### Shut-off function

This parameter can be set separately for each end position. When the associated limit value is up-scaled, the function causes immediate travel of the actuator to the selected end position.

If the value '0' is entered for the corresponding parameter, the position is further controlled, even in the respective end position.

#### Actuator travel time prolongation

This function can be used to increase the max. travel time for full travel. This time parameter can be set separately for each direction.

This function can only be used with the pneumatics with the safety function 'fail-safe'.

#### Switching points for the position

You can use these parameters to define two position limit values for signaling, see option 'Module for digital position feedback'.

#### Digital output

The alarms generated in the positioner can be polled via the digital output as a collective alarm.

The desired information can be selected via the operator panel or remotely via the configuration program.

The output can be set to 'active high' or 'active low', as required.

#### Digital input

For the digital input, one of the following safety options can be selected. You may use the operator's panel or configuration program to select an option.

- No function (standard setting)
  - Move to position 0 %
  - Move to position 100 %
  - Hold previous position
  - Block local parameterization
  - Block local parameterization and operation
  - Block all access (no local or remote access via a PC)
- The selected function is activated when the 24 V signal is no longer connected to the digital input (< 11 V DC).

## ... Device parameters

### Adjustment parameters

The positioner has a special function for automatic adjustment of the parameters. Additionally, the control parameters can be set automatically (in adaptive control mode) or manually to optimally adapt them to the process requirements.

#### Tolerance band

Upon reaching the tolerance band, the position is re-adjusted more slowly until the dead band has been reached.

#### Dead band (sensitivity)

When reaching the dead band, the position is held. The factory setting for this parameter is 0,1 %.

#### Actuator spring action

Selection of the direction of rotation of the sensor shaft (looking at the open housing), if the safe position is approached as a result of the spring force in the actuator (actuator is depressurized via Y1 / OUT1).

For double-acting actuators, the actuator spring action corresponds to pressurizing the pneumatic output (Y2 / OUT2).

#### Display 0 to 100 %

Adjust the display 0 to 100 % in accordance with the direction for opening or closing the final control element.

### Operations monitoring parameters

Various functions for continuous device monitoring are implemented in the operating program for the positioner. The following states will be detected and indicated, e.g.:

- Setpoint signal out of range 4 to 20 mA
- Position out of the adjusted range
- Positioning time up-scaled (adjustable time parameter)
- Positioner inactive
- Counter limits up-scaled (adjustable in diagnosis)

While automatic commissioning is in progress, the current state is continuously indicated on the integrated LCD display. During operation, the LCD shows the most important process variables:

- Current position in %
- Faults, alarms, messages (coded)

Access to extended monitoring parameters is possible via HART communication and the DTM.

### Diagnosis parameters

The diagnostics parameters in the positioner's operating program provide information about the operating conditions of the valve.

From this information the operator can derive what maintenance work is required, and when.

Additionally, limit values can be defined for these parameters. When they are exceeded, an alarm is reported.

So, for example, the following operating values are determined:

- Number of movements of the final control element
- Sum of individual actuator travel events

The diagnosis parameters and limit values can be called up, set, and reset via HART communication, using the configuration program.

### Operator panel

The integrated operating panel of the positioner has four operating buttons which allow the device to be operated with an open housing cover. The following functions can be controlled via the function keys:

- Observe live operation
- Manual intervention during live operation
- Parameterization of the device
- Fully automatic commissioning

The operating panel has a cover to protect against unauthorized operation.



Figure 7: Open TZIDC with a view of the operating panel



### 'One-button' commissioning

Commissioning the positioner is especially easy. Standard Auto Adjust is triggered by pressing a single operating button. Detailed configuration knowledge is not necessary in order to start the device.

Depending on the selected actuator type (linear or rotary actuator), the displayed zero position is automatically adapted:

- for linear actuators counter-clockwise (CTCLOCKW)
- for rotary actuators clockwise (CLOCKW).

Besides this standard function, a customized 'Autoadjust' function is available. The function is launched either via the operator's panel or HART communication.

### LCD display

The multi-line LCD indicator is automatically updated during operation to provide the user with relevant information as necessary.

During control operation (control with or without adaptation) the following data can be called up by pressing the pushbuttons briefly:

- Current set point SP [mA] (up button)
- Electronics temperature [°C, °F, °R, K] (down button)
- Current control deviation DEV [%] (both direction buttons)

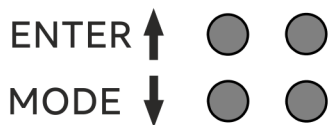
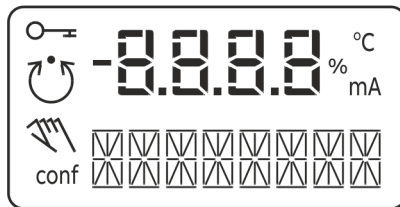

Figure 8: LCD display with operating buttons

## Communication

### FDI – Field Device Integration

The Device Type Driver for the positioner is based on the FDI technology and can either be integrated into a control system or loaded on a PC with ABB Ability™ Field Information Manager (FIM).

This allows you to work with the same user interface in the commissioning phase, during operation, and for service tasks involving monitoring the device, setting parameters, and reading out data.

### DTM

The DTM (Device Type Manager) for the positioner TZIDC is based on FDT / DTM technology (FDT 1.2 / 1.2.1) and can either be integrated into a control system or loaded on a PC with FDT framework. This allows you to work with the same user interface in the commissioning phase, during operation, and for service tasks involving monitoring the device, setting parameters, and reading out data.

Communication is based on the HART® protocol. Communication with the device can take place optionally via an LCI adapter with USB interface on the positioner or an FSK modem at any point on the 20 mA signal line. Reading out data from the device has no effect on the operation in progress. Newly set parameters are saved in the non-volatile memory directly upon download to the device, and become active immediately.

### LCI Adapter

You can easily connect your positioner to a PC, e.g. in the workshop or in the commissioning phase, by using the LCI adapter.

The signals at the USB output of the PC are translated via an LCI adapter to the level of the local communication interface (LCI) of the positioner.

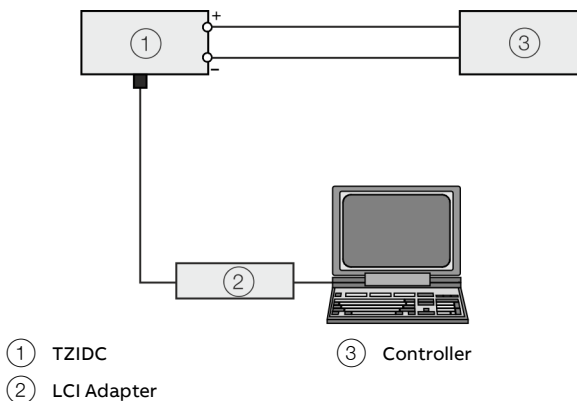

Figure 9: Local communication with LCI adapter

### FSK modem

Digital frequency modulated long distance communication (Frequency Shift Keying) with the positioner is established via the FSK modem.

Tapping is possible at any chosen point of the 20 mA signal line.

We recommend a modem with electrical isolation. This modem is bus-compatible when used with isolating amplifiers. The connection of Ex-field devices is also possible provided the modem is operated outside the Ex area or it corresponds to the Ex approval requirements and the Ex connection data of our device.

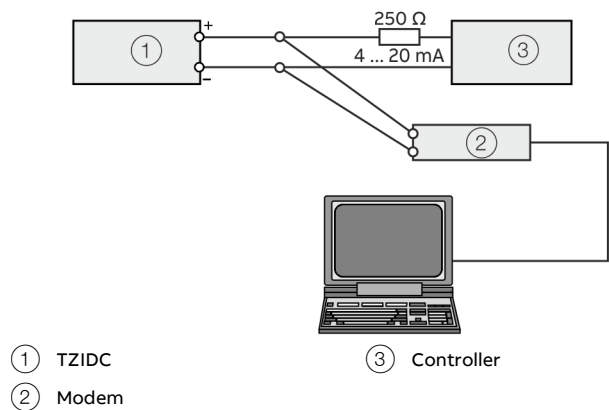

Figure 10: HART communication with modem via 20 mA signal line

### SQUAWK

SQUAWK is a standardized command of the HART®7 communication standard. If a SQUAWK command is sent to the device after connection (HART® command '0'), the flashing of the lower menu line in the display makes it easier to visually identify the affected device in an installation.

## Specification

### Actuator travel

Rotation angle	
Meas. range	270° / 360°*
Operating range for linear actuators	min. 25°, max. 45°
Operating range for rotary actuators	min. 25°, max. <270°, see Figure 11
Actuator travel limit	Min. and max. limits, freely configurable in range of 0 to 100 % of total travel (min. range > 20 %)
Actuator travel time prolongation	Setting range of 0 to 200 seconds, separately for each direction
Dead band time limit	Setting range 0 to 200 seconds (monitoring parameter for the control deviation until the dead band is reached)

\* From HW rev.: 5.01 with order option "S1 – Contactless sensor"

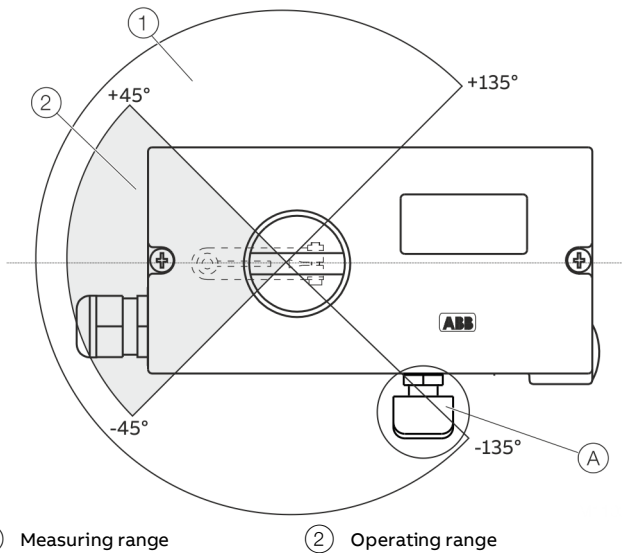

① Measuring range      ② Operating range

Figure 11: Measuring and operating ranges of the positioner

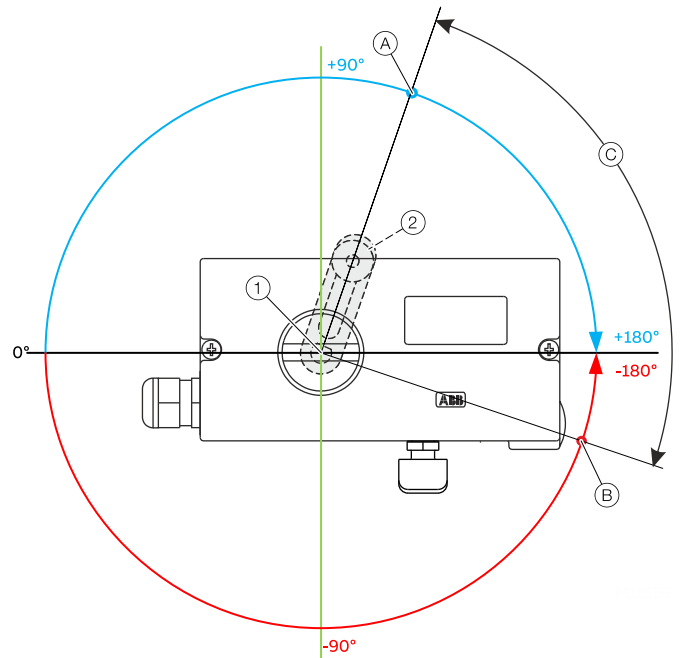

- (A) Operating range 0% opening degree
- (B) Operating range 100% opening degree
- (C) Operating range of the valve/actuator
- (1) Device feedback shaft
- (2) Lever

Figure 12: Measuring and operating range of the positioner from HW rev.: 5.01 with optional contactless position feedback (example)

## ... Specification

### Pneumatic connections

Cable	Air Pipe
Thread ½-14 NPT	Thread ¼-18 NPT
Thread M20 × 1.5	Thread ¼-18 NPT
Thread M20 × 1.5	Thread G ¼
Thread G ½	Thread Rc ¼

(Optional: with cable gland(s) and blind plugs as necessary)

### Compressed air output

Range	Standard design: 0 to 6 bar (0 to 90 psi) Marine version: 0 to 5.5 bar (0 to 80 psi)
Air capacity	> 5 kg/h = 3.9 Nm <sup>3</sup> /h = 2.3 scfm at 1.4 bar (20 psi) supply air pressure > 13 kg/h = 10 Nm <sup>3</sup> /h = 6 scfm at 6 bar (90 psi) supply air pressure
Output function	For single acting or double acting actuators Air is vented from actuator / actuator is blocked in case of (electric) power failure
Shut-off values	End position 0 % = 0 to 45 % End position 100 % = 55 to 100 %

### Instrument air\*

Purity	Maximum particle size: 5 µm Maximum particle density: 5 mg/m <sup>3</sup>
Oil content	Maximum concentration 1 mg/m <sup>3</sup>
Pressure dew point	10 K below operating temperature
Supply pressure**	Standard design: 1.4 to 6 bar (20 to 90 psi) Marine version: 1.6 to 5.5 bar (23 to 80 psi)
Air consumption***	< 0.03 kg/h / 0.015 scfm

\* Free of oil, water and dust in accordance with DIN / ISO 8573-1, pollution and oil content according to Class 3 (except for natural gas variant)

\*\* Do not exceed the maximum output pressure of the actuator

\*\*\* Independent of supply pressure

### Accessories

#### Mounting material

- Attachment kit for linear actuators in accordance with DIN / IEC 534 / NAMUR
- Attachment kit for rotary actuators in accordance with VDI / VDE 3845
- Attachment kit for integral mounting
- Attachment kit for actuator-specific mounting

#### Pressure gauge block

- With pressure gauges for supply air and output pressure. Pressure gauges with housing ø 28 mm (1.10 in), with connection block in aluminum, black
- Installation material in black for mounting on positioner

#### Filter regulator

All metal version in brass, varnished black, bronze filter element (40 µm), with condensate drain.  
Max. pre-pressure 16 bar (232 psi).

Output can be adjusted to:

- 1.4 to 6 bar (20 to 90 psi)

Marine version:

- 1.6 to 5.5 bar (23 to 80 psi)

The filter regulator may only be installed in combination with the pressure gauge block (accessory).

#### PC adapter for communication

- LCI adapter – USB for plug connection to positioner
- HART® – USB modem for HART communication

#### Control program for operation and parameterization on a PC

DAT200 Asset Vision Basic with DTM for TZIDC / TZIDC-200 on CD-ROM.

- Download DTM for TZIDC at: [www.abb.com/positioners](http://www.abb.com/positioners).
- Download ABB Ability™ Field Information Manager (FIM) and FDI package at: [solutions.abb/fieldinfo](http://solutions.abb/fieldinfo).

## Housing

### Material / IP rating

Aluminum with  $\leq 0.1\%$  copper

IP rating IP 65 / NEMA 4X (NEMA 4X does not permit overhead mounting), (IP 66, optional)

### Surface/color

Dipping varnish With epoxy resin, stove-hardened

Housing varnished matt black RAL 9005

Case cover Pantone 420

### Weight

Aluminum 1.7 kg (3.75 lb)

### Mounting orientation

Any

## Transmission data and contributing factors

### Output Y1

Increasing set point signal	0 to 100 % Increasing pressure at output
Decreasing set point signal	0 to 100 % Decreasing pressure at output

### Action (set point signal)

Increasing set point	4 to 20 mA = actuator position 0 to 100 %
Decreasing set point	20 to 4 mA = actuator position 0 to 100 %

### Characteristic curve (actuator travel = f {set point signal})

Linear	Equal percentage 1:25 or 1:50 or 25:1 or 50:1*
Deviation	$\leq 0.5\%$
Tolerance band	0.3 to 10 %, adjustable
Configurable dead zone	0.1 to 10 %, adjustable
Resolution (AD-conversion)	> 16,000 steps
Sampling frequency	20 ms
Ambient temperature effect	$\leq 0.5\%$ per 10 K
Reference temperature	20 °C
Influence of vibration	$\leq 1\%$ to 10 g and 80 Hz

\* freely configurable with 20 reference points

## Seismic vibration

Meets requirements of DIN / IEC 60068-3-3 Class III for strong and strongest earthquakes.

## Influence of mounting orientation

Not measurable.

## Noise emissions

Max. 100 db (A)

Noise-reduced version max. 85 db (A)

## ... Specification

### Communication

- HART protocol 5.9 (standard); optionally HART®7.4
- Local connector for LCI adapter (not in explosion protection area)
- HART communication via 4 to 20 mA signal line with HART compatible modem.

### Environmental conditions

#### Ambient temperature range

During operation, storage, and transport	-40 to 85 °C (-40 to 185 °F)
------------------------------------------	------------------------------

Limit monitor with proximity switches SJ2-SN	-25 to 85 °C (-13 to 185 °F)
----------------------------------------------	------------------------------

TZIDC remote sensor	-40 to 100 °C (-40 to 212 °F)
---------------------	-------------------------------

\* Increased temperature range only with TZIDC Remote Sensor.

#### Relative humidity

During operation with housing closed and air supply switched on	95 % (annual average), condensation permissible
-----------------------------------------------------------------	----------------------------------------------------

Transport and storage	75 % (annual average)
-----------------------	-----------------------

### Safety Integrity Level

Applies to applications with single-acting and depressurizing pneumatics.

The positioner meets the following requirements:

- functional safety in accordance with IEC 61508
- Explosion protection (depending on the version)
- Electromagnetic compatibility in accordance with EN 61000

Without the input signal, the pneumatic module in the positioner vents the actuator and the spring installed in it moves the valve to a predetermined end position (OPEN or CLOSED).

SIL specific safety-related characteristics:

Product	SSF	PFDav	$\lambda_{dd} + \lambda_s$	$\lambda_{du}$
TZIDC with supply current 0 mA	94 %	$1.76 \cdot 10^{-4}$	651 FIT	40 FIT

For details refer to the Management Summary in the SIL Safety Instructions 37/18-79XA.

## Electromagnetic compatibility

Requirement	Component	Standard reference	Test level	Assessment criteria	
				Required	Complied
ESD contact discharge	Chassis	DIN EN 61000-4-2	±4 kV	B	A
ESD air discharge	Chassis	DIN EN 61000-4-2	±8 kV	B	A
Burst 5 kHz	Input/output signals	DIN EN 61000-4-4	±2 kV	B	A
Surge line – line	Input/output signals	DIN EN 61000-4-5	±1 kV	B	A*
Surge line – ground	Input/output signals	DIN EN 61000-4-5	±2 kV	B	A*
radiated interference immunity 80 MHz to 6 GHz	Chassis	DIN EN 61000-4-3	10 V/m	A	A
conducted interference immunity 150 kHz to 80 MHz	Input/output signals	DIN EN 61000-4-6	10 V	A	A
supply frequency magnetic fields	Chassis	DIN EN 61000-4-8	30 A/m	A	A

\* In the event of line surge load on the plug-in module for analog feedback AO, the analog output signal meets assessment criteria B in accordance with DIN EN 61000-4-5.

### Assessment criteria A:

The device must work as intended during and after the test.

### Assessment criteria B:

Impairment in operating performance of the device is permitted during the test. The device must continue to work as intended after the test.

## ... Specification

### Positioner / TZIDC Control Unit Electrical Connection

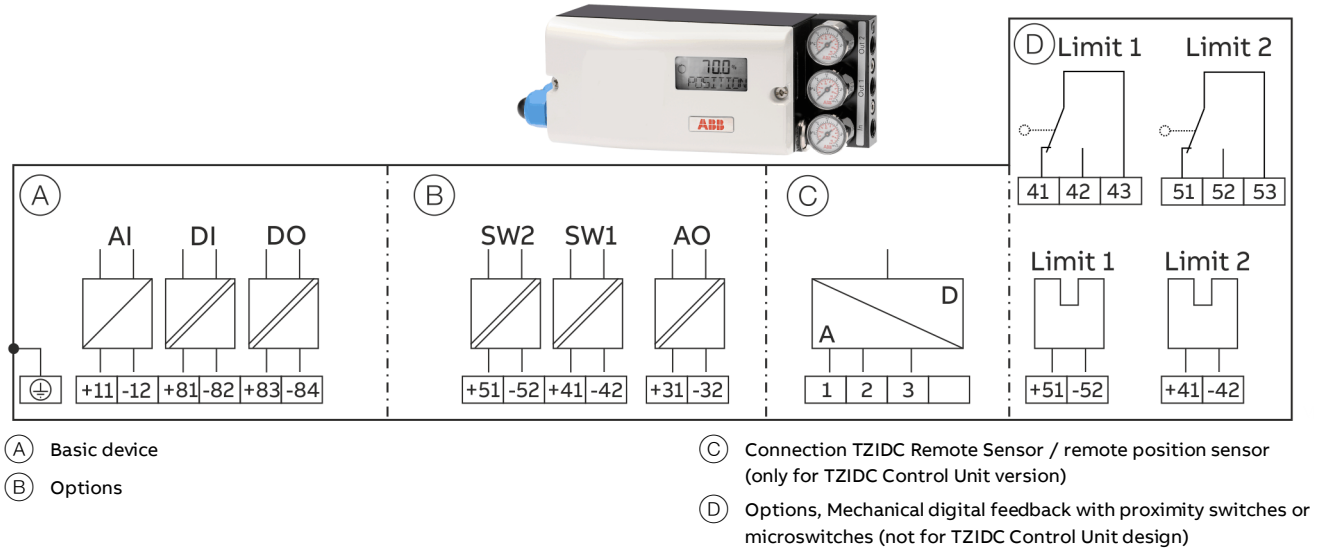

Figure 13: TZIDC Electrical connection

#### Connections for inputs and outputs

Terminal	Function/comments
+11 / -12	<b>Analog input</b>
+81 / -82	<b>Binary input DI</b>
+83 / -84	<b>Binary output DO2</b>
+51 / -52	<b>Plug-in module for digital feedback SW1</b> (Option module)
+41 / -42	<b>Plug-in module for digital feedback SW2</b> (Option module)
+31 / -32	<b>Plug-in module for analog feedback AO</b> (Option module)
1 / 2 / 3	<b>TZIDC remote sensor</b> (Only for options TZIDC Remote Sensor or TZIDC for remote position sensor)

Terminal	Function/comments
+51 / -52	<b>Mechanical digital feedback Limit 1 with proximity switch</b> (optional)
+41 / -42	<b>Mechanical digital feedback Limit 2 with proximity switch</b> (optional)
41 / 42 / 43	<b>Mechanical digital feedback Limit 1 with microswitch</b> (optional)
51 / 52 / 53	<b>Mechanical digital feedback Limit 2 with microswitch</b> (optional)

#### Note

The TZIDC can be fitted either with proximity switches or microswitches as mechanical digital feedback. It is not possible to combine both variants. For the TZIDC Control Unit with TZIDC Remote Sensor version, the mechanical digital feedback is located in the TZIDC Remote Sensor.



## TZIDC Remote Sensor Electrical connection

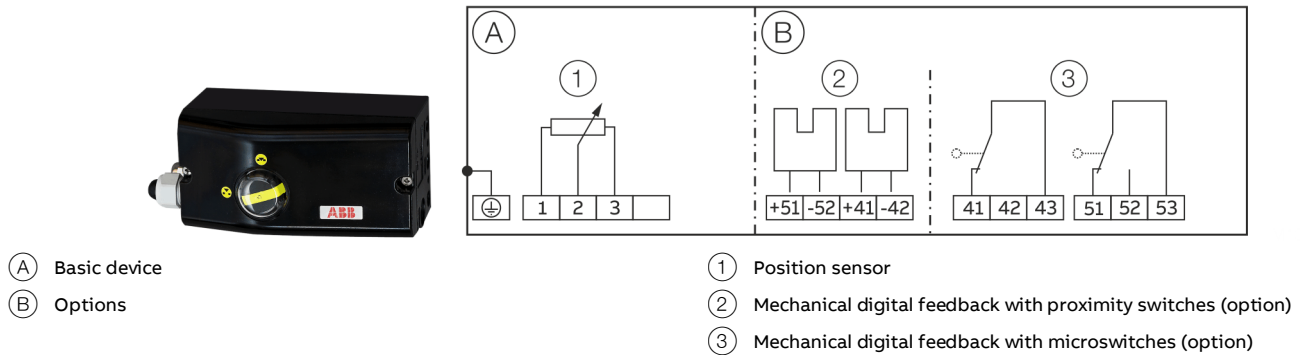

Figure 14: TZIDC Remote Sensor Electrical Connection

### Connections for inputs and outputs

Terminal	Function/comments
1 / 2 / 3	TZIDC control unit
+51 / -52	Mechanical digital feedback Limit 1 with proximity switch (optional)
+41 / -42	Mechanical digital feedback Limit 2 with proximity switch (optional)
41 / 42 / 43	Mechanical digital feedback Limit 1 with microswitch (optional)
51 / 52 / 53	Mechanical digital feedback Limit 2 with microswitch (optional)

#### Note

The TZIDC Remote Sensor can be fitted either with proximity switches or microswitches as mechanical digital feedback. It is not possible to combine both variants. It is not possible to combine both variants.

## Electrical data for inputs and outputs

### Analog input

#### Set point signal analog (two-wire technology)

Terminals	+11 / -12
Nominal operating range	4 to 20 mA
Split range configuration between	20 to 100 % of the nominal operating range can be parameterized
Maximum	50 mA
Minimum	3.6 mA
Starting at	3.8 mA
Load voltage	9.7 V at 20 mA
Impedance at 20 mA	485 Ω

### Digital input

Input for the following functions:

- no function
- move to 0 %
- move to 100 %
- Hold previous position

- block local configuration
- block local configuration and operation
- block any access (local or via PC)

#### Binary input DI

Terminals	+81 / -82
Supply voltage	24 V DC (12 to 30 V DC)
Input 'logical 0'	0 to 5 V DC
Input 'logical 1'	11 to 30 V DC
Input Current	maximum 4 mA

#### Digital output DO

Output configurable as alarm output by software.

#### Binary output DO

Terminals	+83 / -84
Supply voltage	5 to 11 V DC (Control circuit in accordance with DIN 19234/NAMUR)
Output 'logical 0'	> 0.35 mA to < 1.2 mA
Output 'logical 1'	> 2.1 mA
Direction of action	Configurable 'logical 0' or 'logical 1'

## ... Specification

### ... Electrical data for inputs and outputs

#### Plug-in module for analog feedback AO\*

Without any signal from the positioner (e.g. 'no power' or 'initializing') the module sets the output to > 20 mA (alarm level).

Terminals	+31 / -32
Signal range	4 to 20 mA (split ranges can be parameterized)
• in the event of an error > 20 mA (alarm level)	
Supply voltage, two-wire technology	24 V DC (11 to 30 V DC)
Characteristic curve	rising or falling (configurable)
Deviation	< 1 %

#### Plug-in module for digital feedback SW1, SW2\*

Two software switches for binary position feedback (position adjustable within the range of 0 to 100 %, ranges cannot overlap)

Terminals	+41 / -42, +51 / -52
Supply voltage	5 to 11 V DC (Control circuit in accordance with DIN 19234 / NAMUR)
Output 'logical 0'	< 1.2 mA
Output 'logical 1'	> 2.1 mA
Direction of action	Configurable 'logical 0' or 'logical 1'

\* The module for analog feedback and the module for digital feedback have separate slots and can be used together.

#### Mechanical digital feedback

Two proximity switches or microswitches for independent signaling of the actuator position, switching points are adjustable between 0 bis 100 %.

#### Feedback on the actuator position using proximity switches Limit 1, Limit 2

Terminals	+41 / -42, +51 / -52	
Supply voltage	5 to 11 V DC (Control circuit in accordance with DIN 19234/NAMUR)	
Direction of action	Metal tag in the proximity switch	Metal tag outside the proximity switch
Type S12-SN (NC; log 1)	< 1.2 mA	> 2.1 mA

#### Feedback on the actuator position using microswitches Limit 1, Limit 2

Terminals	+41 / -42, +51 / -52
Supply voltage	maximum 24 V AC/DC
Load rating	Maximum 2 A
Contact surface	10 µm Gold (AU)

#### Mechanical position indicator

Indicator disk in enclosure cover linked with device feedback shaft.

These options are also available for retrofitting by Service.

## Wire cross-sectional areas

### Basic device

<b>Electrical connections</b>	
4 to 20 mA input	Screw terminals max. 2.5 mm <sup>2</sup> (AWG14)
Options	Screw terminals max. 1.0 mm <sup>2</sup> (AWG18)
<b>Cross section</b>	
Rigid / flexible wires	0.14 to 2.5 mm <sup>2</sup> (AWG26 to AWG14)
Flexible with wire end sleeve	0.25 to 2.5 mm <sup>2</sup> (AWG23 to AWG14)
Flexible with wire end sleeve no plastic sleeve	0.25 to 1.5 mm <sup>2</sup> (AWG23 to AWG17)
Flexible with wire end sleeve with plastic sleeve	0.14 to 0.75 mm <sup>2</sup> (AWG26 to AWG20)
<b>Multi-wire connection capacity (two wire with the same cross-section)</b>	
Rigid / flexible wires	0.14 to 0.75 mm <sup>2</sup> (AWG26 to AWG20)
Flexible with wire end sleeve no plastic sleeve	0.25 to 0.75 mm <sup>2</sup> (AWG23 to AWG20)
Flexible with wire end sleeve with plastic sleeve	0.5 to 1.5 mm <sup>2</sup> (AWG21 to AWG17)

### Option modules

<b>Cross section</b>	
Rigid / flexible wires	0.14 to 1.5 mm <sup>2</sup> (AWG26 to AWG17)
Flexible with wire end sleeve no plastic sleeve	0.25 to 1.5 mm <sup>2</sup> (AWG23 to AWG17)
Flexible with wire end sleeve with plastic sleeve	0.25 to 1.5 mm <sup>2</sup> (AWG23 to AWG17)
<b>Multi-wire connection capacity (two wire with the same cross-section)</b>	
Rigid / flexible wires	0.14 to 0.75 mm <sup>2</sup> (AWG26 to AWG20)
Flexible with wire end sleeve no plastic sleeve	0.25 to 0.5 mm <sup>2</sup> (AWG23 to AWG22)
Flexible with wire end sleeve with plastic sleeve	0.5 to 1 mm <sup>2</sup> (AWG21 to AWG18)
<b>Feedback on the actuator position using proximity switches or microswitches</b>	
Rigid wire	0.14 to 1.5 mm <sup>2</sup> (AWG26 to AWG17)
Flexible wire	0.14 to 1.0 mm <sup>2</sup> (AWG26 to AWG18)
Flexible with wire end sleeve no plastic sleeve	0.25 to 0.5 mm <sup>2</sup> (AWG23 to AWG22)
Flexible with wire end sleeve with plastic sleeve	0.25 to 0.5 mm <sup>2</sup> (AWG23 to AWG22)

## Dimensions

All dimensions in mm (in)

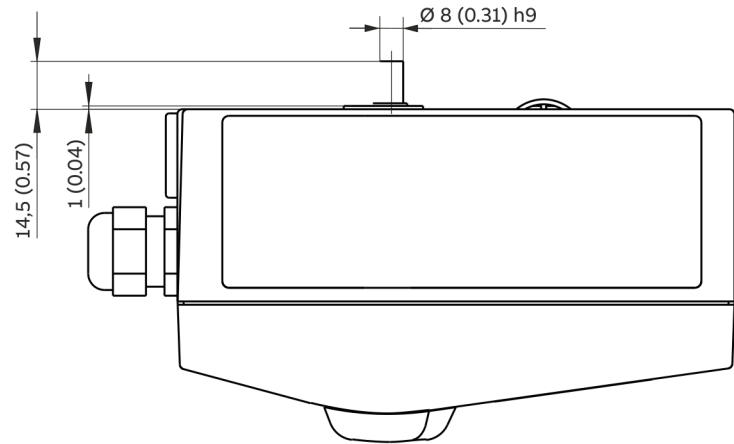
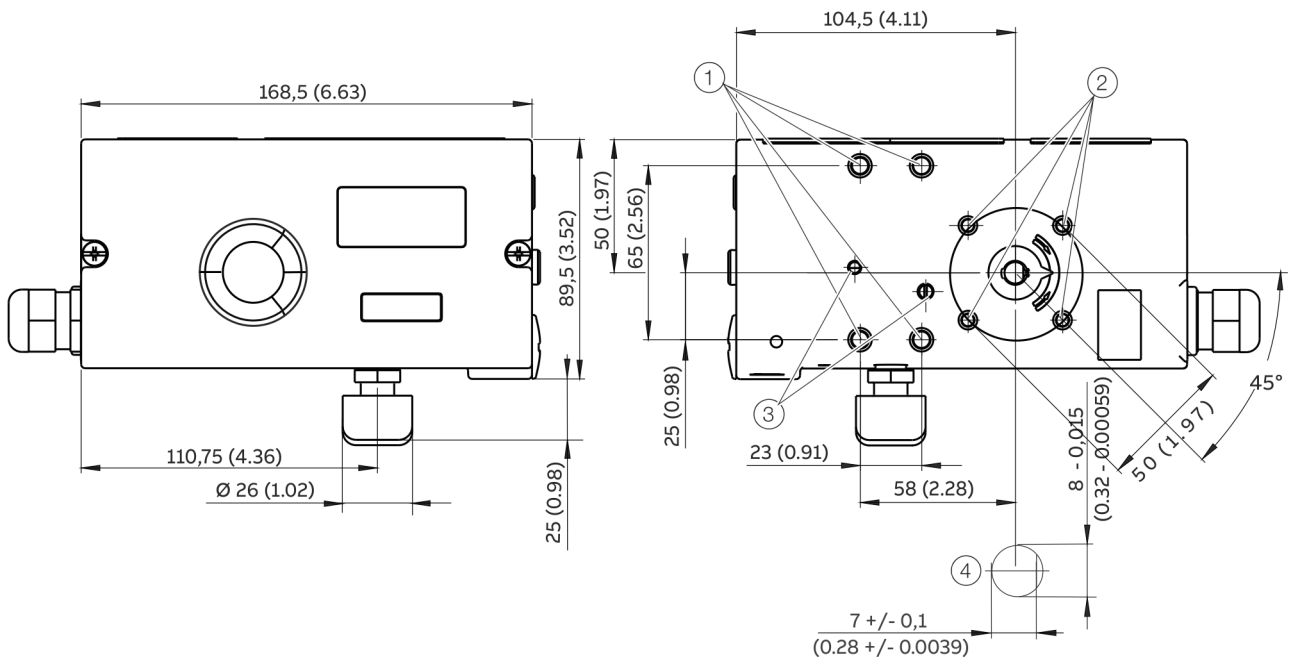

Figure 15: Top view



① Tap hole M8 (10 mm [0.39 in] deep)

② Tap hole M6 (8 mm deep [0.31 in])

③ Threaded hole M5 × 0.5 (air outputs for direct mount)

④ Sensor shaft (shown larger than scale)

Figure 16: Front and rear view

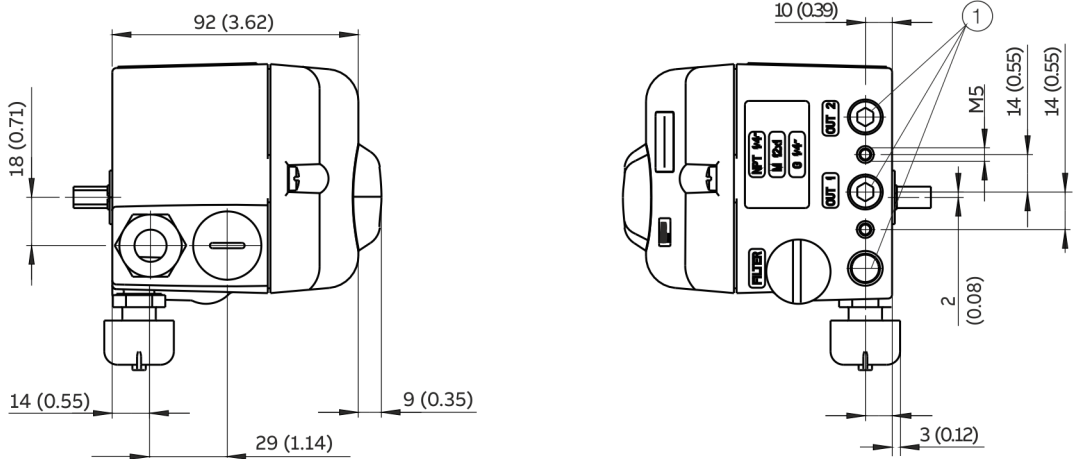

① Pneumatic connections, NPT ¼ in-18 or G ¼

Figure 17: Side view (from left to right)

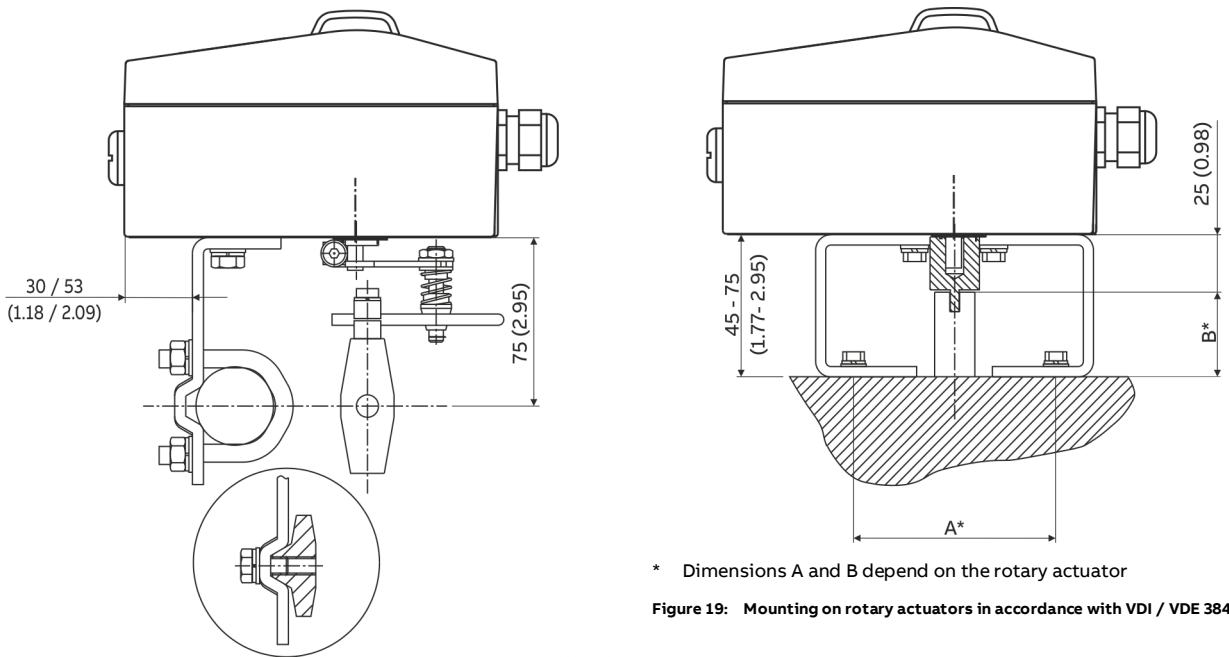

Figure 18: Mounting to linear actuators in accordance with DIN / IEC 534

\* Dimensions A and B depend on the rotary actuator  
 Figure 19: Mounting on rotary actuators in accordance with VDI / VDE 3845

## ... Dimensions

### ... Electrical data for inputs and outputs

All dimensions in mm (in)

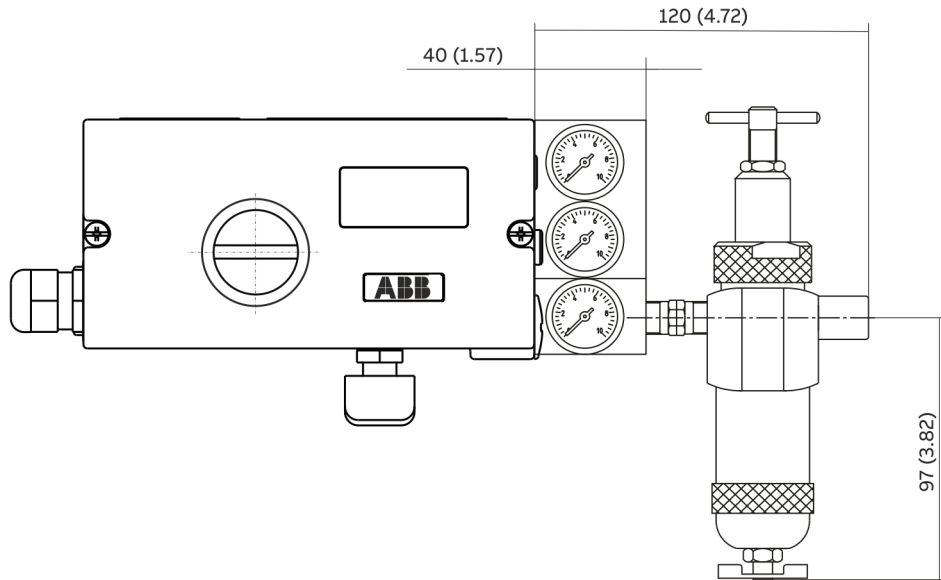

Figure 20: Positioner DS\_TZIDC\_EN\_G with mounted pressure gauge block and filter regulator

## Use in potentially explosive atmospheres

### General requirements

- The ABB positioner has been approved only for appropriate and intended use in standard industrial atmospheres. Any breach of this rule leads to a cancellation of warranty and manufacturer's responsibility!
- Make sure that only devices which comply with the types of protection relevant to the applicable zones and categories are installed.
- All electric equipment has to be suited for the respective intended use.

### Approvals and certifications

The digital positioner TZIDC has a variety of different explosion protection approvals. The scope of these approvals extends over the entire EU, Switzerland, and special countries.

They range from explosion protection approvals in accordance with ATEX directives to internationally recognized approvals such as IECEx, and additionally include country-specific explosion protection approvals.

#### Explosion protection approvals

- ATEX / UKEX, for details, see page 27.
- IECEx, for details, see page 29.
- cFMus, for details, see page 31.
- EAC TR-CU-012, for details see page 40.

#### Standards applied

The standards including the date of issue with the devices are in compliance are specified in the EU Type examination certificate and in the declaration of conformity of the manufacturer.

### Product identification

Depending on the type of explosion protection, Ex-marking is attached to the positioner on the right, next to the main name plate.

This indicates the level of explosion protection and the device's relevant Ex certificate.

#### Marking (name plate)



Figure 21: Ex marking (example, ATEX / IECEx)



Figure 22: Ex marking (example, UKEX)



Figure 23: Ex marking (example, cFMus)



Figure 24: Ex marking (example, EAC Ex)

## ... Use in potentially explosive atmospheres

### Commissioning, Installation

The ABB positioner has to be mounted in a major system. Depending on the degrees of IP-protection, an interval for cleaning the equipment (dust settlement) has to be defined. Strict care has to be taken that only devices which comply with the types of protection relevant to the applicable zones and categories is installed.

When installing the device, the locally applicable installation regulations, such as EN 60079-14, must be observed.

Other important facts to be observed:

- The electric circuits of the positioner must be put into operation in all zones by persons qualified in accordance with TRBS 1203. The details on the type label are mandatory for doing this.
- The device has been designed in accordance with IP 65 (optionally IP 66) and must be protected accordingly against adverse ambient conditions.
- In accordance with the selected Ex approval, the information in the EU type examination certificate or the Ex certificates must be observed, including the special conditions defined in them.
- The device may only be used in accordance with its intended use.
- The device may only be connected when de-energized.
- The potential equalization of the system must be established in accordance with installation regulations applicable in the respective country (VDE 0100, Part 540, IEC 364-5-54).
- Circulating currents must not be guided through the housing!
- Make sure that the housing is properly installed and that its IP rating has not been compromised.
- In potentially explosive atmospheres, assembly may be conducted only in compliance with locally applicable installation regulations. The following conditions have to be observed (incomplete):
  - Assembly and maintenance may only be conducted if there is no explosion hazard in the area and you have a hot work permit.
  - The TZIDC may be operated in a fully mounted and intact housing only.

### Notes for operation

- The positioner must be integrated in the local potential equalization system.
- Only either intrinsically safe or non intrinsically safe circuits may be connected. A combination is not permitted.
- If the positioner is operated with non intrinsically safe circuits, later use for the intrinsic safety type of protection is not permitted.

### Use, Operation

The TZIDC is approved for proper and intended use only. In case of non-compliance, the warranty and manufacturer's liability do no longer apply!

- Only those auxiliary components which fulfill all the requirements of European and national standards may be used in potentially explosive atmospheres.
- The ambient conditions specified in the operating instruction must be strictly followed.
- The TZIDC is approved for proper and intended use in standard industrial atmospheres only. Where aggressive substances are present in the air, the manufacturer has to be consulted.



## Maintenance, repair

Definition of terms according to IEC 60079-17:

### Maintenance

Defines a combination of actions performed to maintain or restore the condition of an item such that the item meets the requirements of the relevant specification and performs its required functions.

### I –Analyzer module without electronics module (power supply):

Defines an action which involves careful inspection of an item (either without disassembly or with partial disassembly, as required) supplemented by measurements, aimed at achieving a reliable conclusion regarding the condition of the item.

### Visual inspection

Defines an inspection which identifies defects which are visible to the naked eye, such as missing screws, without the use of access equipment and tools.

### Close inspection

Defines an inspection which encompasses the aspects covered by a visual inspection and in addition, identifies defects such as loose screws, which can only be detected with the use of access equipment (e.g. steps) and tools.

### Detailed inspection

Defines an inspection which encompasses the aspects covered by a close inspection and in addition, identifies defects, such as loose connections, which can only be detected by opening the housing and / or by using tools and test devices, as needed.

- Maintenance and exchange work may be conducted by qualified specialists only, i.e., qualified personnel in accordance with TRBS 1203 or similar.
- Only those auxiliary components which fulfill all the requirements of European and national guidelines and regulations may be used in potentially explosive atmospheres.
- Maintenance works that require disassembly of the system may only be performed in non-hazardous areas. If that is not possible, however, the usual precautions have to be ensured according to local regulations.
- Components may only be replaced by original spare parts which are therefore approved for use in potentially explosive atmospheres.
- The device must be regularly cleaned when used in potentially explosive atmospheres. The intervals must be defined by the operator in compliance with the ambient conditions present at the operating location.
- After all maintenance and repair work has been completed, any barriers and plates removed for that purpose must be put back in their original place.
- The flameproof joints differ from the tables of IEC 60079-1 and may be repaired by the manufacturer only.

Activity	Visual inspection (every 3 months)	Close inspection (every 6 months)	Detailed inspection (every 12 months)
Visual inspection of the positioner for integrity, removal of dust deposits	●		
Inspection of electric installation for integrity and proper operation			●
Inspection of the entire installation		Responsibility of the operator	

---

## ... Use in potentially explosive atmospheres

### Preconditions for safe operation of the positioner

When using in hazardous areas, observe the following points:

- Observe the specification and special conditions applicable for the device in accordance with the relevant valid certificate.
- Manipulation of the device in any form by the user is not permitted. Only the manufacturer or an explosion protection specialist may modify the device
- The IP 65 / NEMA 4x IP rating is only achieved if the splash guard is screwed in place. Operating the unit without splash guard cap is prohibited.
- The device may only be operated using instrument air that is free from oil, water and dust. The use of flammable gas, oxygen, or oxygen-enriched gas is not permitted.
- High / recurring charging processes in gas zones must be excluded by the operator.

### Cable gland

Limited temperature range of the M20 × 1.5 plastic cable gland for explosion protection variants:

- The permissible ambient temperature range is -20 to 80 °C (-4 to 176 °F).
- When using the cable gland, you need to make sure that the ambient temperature is within the permissible range plus 10 K or that they are suited in terms of the minimal ambient temperature.
- The cable gland must be installed in the housing with a tightening torque of 3.8 Nm. When installing the connection of the cable gland and cable, check for tightness to ensure that the required IP rating is met.

## ATEX / UKEX

### Type of protection Ex i, intrinsic safety

#### Ex-marking

Ex marking	
Marking	II 2 G Ex ia IIC T6/ T4...T1 Gb II 2 G Ex ib IIC T6/ T4 ...T1 Gb II 3 G Ex ic IIC T6/T4 ... T1 Gc
Type Examination Test Certificate	TÜV 04 ATEX 2702 X
Certificate (UKEX)	EMA22UKEX0032X
Type of protection	Intrinsic safety 'i'
Device class	II 2G / II 3G
Standards	EN 60079-0, EN 60079-11

#### Special conditions

- The power supply for the 'Feedback on the actuator position using proximity switches (Pepperl & Fuchs SJ2-SN)' circuit must be provided intrinsically safe in accordance with the PTB 00 ATEX 2049 X certificate according to application type 2.
- It is only permissible to connect, disconnect, and switch live circuits during installation or maintenance, or for the purpose of carrying out repairs.

#### Note

It is considered very unlikely that a potentially hazardous atmosphere would be present in Zone 2 at the same time that installation or maintenance or repair work was being carried out.

- Only non-flammable gases must be used for pneumatic power supply.
- When used with gases from group IIA and a temperature class of T1 for pneumatic power supply, the positioner TZIDC may only be used outdoors or inside sufficiently ventilated buildings.
- For TZIDC, the gas supplied must be kept sufficiently free of air and oxygen to prevent an ignitable atmosphere from forming. The exhaust gas must always be discharged outside.
- Only use suited cable entries that meet the requirements of EN 60079-11.

#### Temperature Data

##### Device group II 2 G / II 3 G

Temperature class	Ambient temperature Ta
T4 to T1	-40 to +85 °C
T6*	-40 to 40 °C*

\* When using the 'Plug-in module for digital feedback' in temperature class T6, the maximum permissible ambient temperature range is -40 to +35 °C.

#### Electrical Data

In type of protection 'Intrinsic safety Ex ib, Ex ia or Ex ic', only for connection to a certified intrinsically safe circuit.

##### Current circuit (terminal) Electrical information (maximum values)

Signal circuit (+11 / -12)	U <sub>i</sub> = 30 V I <sub>i</sub> = 320 mA P <sub>i</sub> = 1.1 W	C <sub>i</sub> = 6.6 nF L <sub>i</sub> = negligibly small
Contact input (+81 / -82)	U <sub>i</sub> = 30 V I <sub>i</sub> = 320 mA P <sub>i</sub> = 1.1 W	C <sub>i</sub> = 14.5 nF L <sub>i</sub> = negligibly small
Switch output (+83 / -84)	U <sub>i</sub> = 30 V I <sub>i</sub> = 320 mA P <sub>i</sub> = 500 mW	C <sub>i</sub> = 14.5 nF L <sub>i</sub> = negligibly small
Feedback on the actuator position using proximity switches, (Pepperl & Fuchs SJ2-SN) (Limit1: +51 / -52), (Limit2: +41 / -42)	For maximum values, see EU-Type examination certificate PTB 00 ATEX 2049 X Pepperl & Fuchs Type 2 proximity switches	
Plug-in module for digital feedback (+51 / -52) (+41 / -42)	U <sub>i</sub> = 30 V I <sub>i</sub> = 320 mA P <sub>i</sub> = 250 mW	C <sub>i</sub> = 3.7 nF L <sub>i</sub> = negligibly small
Plug-in module for analog feedback (+31 / -32)	U <sub>i</sub> = 30 V I <sub>i</sub> = 320 mA P <sub>i</sub> = 1.1 W	C <sub>i</sub> = 6.6 nF L <sub>i</sub> = negligibly small
Interface with the TZIDC Remote Sensor (X2-2: +Uref, X3-2: GND, X3-1: Signal)	U <sub>0</sub> = 5.4 V I <sub>0</sub> = 74 mA P <sub>0</sub> = 100 mW C <sub>i</sub> = negligibly small L <sub>i</sub> = negligibly small	Ex ia or Ex ib type of protection IIC: L <sub>0</sub> = 5 mH C <sub>0</sub> = 2 µF IIB: L <sub>0</sub> = 5 mH C <sub>0</sub> = 10 µF
Local communication interface (LCI)	Only for connection to a programming device using an ABB LCI adapter (Um ≤ 30 V DC) outside the hazardous area.	

## ... Use in potentially explosive atmospheres

### ... ATEX / UKEX

#### Type of protection Ex ec – increased safety

##### Ex marking

Ex marking	
Marking	II 3 G Ex ec IIC T6, T4...T1 Gc
Type Examination Test Certificate	TÜV 04 ATEX 2702 X
Certificate (UKEX)	EMA22UKEX0032X
Type	Equipment for increased safety
Device class	II 3 G
Standards	EN 60079-0, EN 60079-7

#### Special conditions

- For the 'Feedback on the actuator position using proximity switches (Pepperl & Fuchs SJ2-SN)' circuit, measures outside of the device must be implemented to prevent an up-scale of the rated voltage by more than 40% in the event of transient disturbances.
- It is only permissible to connect, disconnect, and switch live circuits during installation or maintenance, or for the purpose of carrying out repairs.

##### Note

It is considered very unlikely that a potentially hazardous atmosphere would be present in Zone 2 at the same time that installation or maintenance or repair work was being carried out.

- Only non-flammable gases must be used for pneumatic power supply.
- Only use suited cable entries that meet the requirements of EN 60079-7.

In the case of TZIDC, the following shall apply for safe use in the Ex 'ec IIC' type of protection:

- Only devices that are suited for operation in hazardous areas of Zone 2 and the conditions prevailing at the place of use may be connected to circuits in Zone 2 (manufacturer's declaration or certificate from the test center).

#### Temperature Data

##### Device group II 3 G

Temperature class	Ambient temperature Ta
T4 to T1	-35 to +85 °C
T6*	-35 to +50 °C*

\* When using the 'Plug-in module for digital feedback' in temperature class T6, the maximum permissible ambient temperature range is -35 to +35 °C.

#### Electrical Data

In 'Increased safety Ex ec' type of protection only for connection to a certified circuit for increased safety.

##### Current circuit (terminal) Electrical information (maximum values)

Signal circuit (+11 / -12)	U = 9.7 V DC I = 4 to 20 mA, max. 21.5 mA
Contact input (+81 / -82)	U = 12 to 24 V DC I = 4 mA
Switch output (+83 / -84)	U = 11 V DC
Feedback on the actuator position using proximity switches, (Pepperl & Fuchs SJ2-SN) (Limit1: +51 / -52), (Limit2: +41 / -42)	U = 8,2 V (Ri approx. 1 kΩ)
Plug-in module for digital feedback (+51 / -52) (+41 / -42)	U = 5 to 11 V DC
Plug-in module for analog feedback (+31 / -32)	U = 10 to 30 V DC I = 4 to 20 mA, max. 21.5 mA
Local communication interface (LCI)	Only for connection to a programming device using an ABB LCI adapter (Um ≤ 30 V DC) outside the hazardous area.

## IECEX

### Type of protection Ex i, intrinsic safety

#### Ex marking

Ex marking	
Marking	Ex ia IIC T6 resp. T4...T1 Gb Ex ib IIC T6 resp. T4...T1 Gb Ex ic IIC T6 resp. T4...T1 Gc
Type Examination Test Certificate	IECEX TUN 04.0015X
Type	Intrinsic safety 'i'
Standards	IEC 60079-0, IEC 60079-11

#### Special conditions

- The power supply for the 'Feedback on the actuator position using proximity switches (Pepperl & Fuchs SJ2-SN)' circuit must be provided intrinsically safe in accordance with the PTB 00 ATEX 2049 X certificate according to application type 2.
- It is only permissible to connect, disconnect, and switch live circuits during installation or maintenance, or for the purpose of carrying out repairs.

#### Note

It is considered very unlikely that a potentially hazardous atmosphere would be present in Zone 2 at the same time that installation or maintenance or repair work was being carried out.

- Only non-flammable gases must be used for pneumatic power supply.
- When used with gases from group IIA and a temperature class of T1 for pneumatic power supply, the positioner TZIDC may only be used outdoors or inside sufficiently ventilated buildings.
- For TZIDC, the gas supplied must be kept sufficiently free of air and oxygen to prevent an ignitable atmosphere from forming. The exhaust gas must always be discharged outside.
- Only use suited cable entries that meet the requirements of EN 60079-11.

### Temperature Data

Temperature class	Ambient temperature Ta
T4 to T1	-40 to +85 °C
T6*	-40 to 40 °C*

\* When using the 'Plug-in module for digital feedback' in temperature class T6, the maximum permissible ambient temperature range is -40 to +35 °C.

### Electrical Data

In type of protection 'Intrinsic safety Ex ib, Ex ia or Ex ic', only for connection to a certified intrinsically safe circuit.

Current circuit (terminal)	Electrical information (maximum values)	
Signal circuit (+11 / -12)	U <sub>i</sub> = 30 V I <sub>i</sub> = 320 mA P <sub>i</sub> = 1.1 W	C <sub>i</sub> = 6.6 nF L <sub>i</sub> = negligibly small
Contact input (+81 / -82)	U <sub>i</sub> = 30 V I <sub>i</sub> = 320 mA P <sub>i</sub> = 1.1 W	C <sub>i</sub> = 14.5 nF L <sub>i</sub> = negligibly small
Switch output (+83 / -84)	U <sub>i</sub> = 30 V I <sub>i</sub> = 320 mA P <sub>i</sub> = 500 mW	C <sub>i</sub> = 14.5 nF L <sub>i</sub> = negligibly small
Local communication interface (LCI)	Only for connection to a programming device using an ABB LCI adapter (U <sub>m</sub> ≤ 30 V DC) outside the hazardous area.	

The following modules may be operated as an option:

Current circuit (terminal)	Electrical information (maximum values)	
Feedback on the actuator position using proximity switches, (Pepperl & Fuchs SJ2-SN) (Limit1: +51 / -52), (Limit2: +41 / -42)	For maximum values, see certificate IECEx PTB 11.0092X Pepperl & Fuchs Type 2 proximity switches	
Plug-in module for digital feedback (+51 / -52) (+41 / -42)	U <sub>i</sub> = 30 V I <sub>i</sub> = 320 mA P <sub>i</sub> = 250 mW	C <sub>i</sub> = 3.7 nF L <sub>i</sub> = negligibly small
Plug-in module for analog feedback (+31 / -32)	U <sub>i</sub> = 30 V I <sub>i</sub> = 320 mA P <sub>i</sub> = 1.1 W	C <sub>i</sub> = 6.6 nF L <sub>i</sub> = negligibly small

## ... Use in potentially explosive atmospheres

### ... IECEx

#### Type of protection Ex e – increased safety, Ex n – non-sparking

##### Ex marking

##### IECEx Ex ec

Marking	Ex ec IIC T6 resp. T4...T1 Gc
Type Examination Test Certificate	IECEx TUN 04.0015X
Type	Increased safety
Standards	IEC 60079-0, IEC 60079-7

##### IECEx Ex nA

Marking	Ex nA IIC T6 resp. T4...T1 Gc
Type Examination Test Certificate	IECEx TUN 04.0015X
Type	IP rating 'n'
Standards	IEC 60079-0, IEC 60079-15

#### Temperature Data

Temperature class	Ambient temperature Ta
T4 to T1	-35 to +85 °C
T6*	-35 to +50 °C*

\* When using the 'Plug-in module for digital feedback' in temperature class T6, the maximum permissible ambient temperature range is -35 to +35 °C.

#### Special conditions

- For the 'Feedback on the actuator position using proximity switches (Pepperl & Fuchs SJ2-SN)' circuit, measures outside of the device must be implemented to prevent an up-scale of the rated voltage by more than 40% in the event of transient disturbances.
- Only devices that are suited for operation in hazardous areas of Zone 2 and the conditions prevailing at the place of use may be connected to circuits in Zone 2 (manufacturer's declaration or certificate from the test center).
- It is only permissible to connect, disconnect, and switch live circuits during installation or maintenance, or for the purpose of carrying out repairs.

##### Note

It is considered very unlikely that a potentially hazardous atmosphere would be present in Zone 2 at the same time that installation or maintenance or repair work was being carried out.

- Only non-flammable gases must be used for pneumatic power supply.
- Only use suited cable entries that meet the requirements of EN 60079-7 or EN 60079-15.

#### Electrical Data

In the 'increased safety Ex ec or non-sparking Ex nA' type of protection only for connection to a certified intrinsically safe circuit.

##### Current circuit (terminal) Electrical information (maximum values)

Signal circuit (+11 / -12)	U = 9.7 V DC I = 4 to 20 mA, max. 21.5 mA
Contact input (+81 / -82)	U = 12 to 24 V DC I = 4 mA
Switch output (+83 / -84)	U = 11 V DC
Local communication interface (LCI)	Only for connection to a programming device using an ABB LCI adapter (Um ≤ 30 V DC) outside the hazardous area.

The following modules may be operated as an option:

##### Current circuit (terminal) Electrical information (maximum values)

Feedback on the actuator position using proximity switches, (Pepperl & Fuchs SJ2-SN) (Limit1: +51 / -52), (Limit2: +41 / -42)	U = 8.2 V (Ri approx. 1 kΩ)
Plug-in module for digital feedback (+51 / -52) (+41 / -42)	U = 5 to 11 V DC
Plug-in module for analog feedback (+31 / -32)	U = 10 to 30 V DC I = 4 to 20 mA, max. 21.5 mA

## cFMus

### Ex marking

#### TZIDC without mechanical position indication

**Model number: V18345-10b2c2de0f or V18345-30b2c2de0f**

IS / I, II, III / 1 / ABCDEFG / T6, T4 Ta = 40°C, 85°C - 901265; Entity

NI / I, II, III / 2 / ABCDEFG / T6, T4 Ta = 40°C, 85°C

Type 4X; IP65

Max Entity Parameters: Per Control Drawings

Certificate FM20US0122X und FM20CA0061X

#### TZIDC with mechanical position indication

**Model number: V18345-20b2c2de0f or V18345-40b2c2de0f**

IS / I / 1 / ABCD / T6, T4 Ta = 40°C, 85°C - 901265; Entity

IP65

Max Entity Parameters: Per Control Drawings

Certificate FM20US0122X und FM20CA0061X

### Model number details

- b Set input / communication port: 1 or 2.
- c Set output / safety position: 1, 2, 4 or 5.
- d Optional upgrade with plug-in module for analog / digital feedback (option): 0, 1, 3 or 5.
- e Optional upgrade with mechanical digital feedback (option): 0, 1 or 2.
- f Design (painting / marking): 1, H, P, S or 2

### Temperature Data

Temperature class	Ambient temperature Ta
T4 T125 °C	-40 °C < Ta < 85 °C
T6 T85 °C	-40 °C < Ta < 40 °C

### Electrical Data

Refer to **FM installation drawing No. 901265** on page 35.

### Commissioning, installation

The ABB positioner has to be mounted in a major system. Depending on the degrees of IP-protection, an interval for cleaning the equipment (dust settlement) has to be defined. Strict care has to be taken that only such equipment is installed that complies with the types of protection relevant to the applicable zones and categories.

When installing the equipment, the locally applicable rules on erection, have to be observed, see **Page 4 of 5** on page 38 to **Page 5 of 5** on page 39.

Other important facts to be observed:

- The equipment is constructed for IP 66 and has to be protected accordingly in adverse ambient conditions.
- The Certificates have to be taken into account including any special conditions defined therein.
- The equipment shall only be used as intended.
- The equipment is only to be connected when de-energized.
- The potential equalization of the system has to be established according to the regulations of erection applicable in the respective country of use, see **Page 4 of 5** on page 38 to **Page 4 of 5** on page 38. For installation according to the North American Zone concept the external grounding is supplementary.
- Circulating currents shall not be led via the enclosures!
- It has to be ensured that the enclosure is properly installed and that its IP protection is not impaired.
- Inside the potentially explosive atmospheres' assembly shall only be performed taking the locally applicable rules of erection into account.

## ... Use in potentially explosive atmospheres

### ... cFMus

The following conditions have to be observed (incomplete):

- Assembly and maintenance to be done only if atmosphere is Ex-free and a permit for hot works is in place.
- The TZIDC is only to be operated in a fully mounted and intact enclosure.
- Outside of the housing is a connector for the equipotential bonding.

The following opportunities are available:

- Direct connection of single-strand wires of up to 2.5 mm<sup>2</sup> or
- Direct connection of fine wires of up to 1.5 mm<sup>2</sup> or
- Connection of cross-sections of up to 6 mm<sup>2</sup> using a ring or spade terminal with 4 mm drill hole.
- For proper selection of cables see electrical installation instructions in the original manufacturer's manual. Use cables rated at least 20 K greater than the ambient temperature.
- High / recurring charging processes in gas areas must be excluded by the operator.

### Notes for operation

- The positioner shall be included in the local equipotential bonding system
- Either only intrinsically or non intrinsically safe circuits shall be connected. A combination is not permitted.
- When the Positioner is operated with non intrinsically safe circuits, the subsequent use for type of protection Intrinsic Safety is not permitted.

### Special conditions for the safe use of intrinsically safe positioners

#### Special conditions

- The 'Local communication interface (LCI)' may only be used outside of the explosion hazardous area with  $U_m \leq 30$  V DC.
- Measures of lightning protection have to be provided by the user.

#### Special conditions for safe use of Positioners non I.S.

- Only devices which are suitable for the operation in explosion hazardous areas declared as zone 2 and the conditions available at the place of operation are allowed to be connected to circuits in the zone 2.
- The connecting and disconnecting as well as the switching of circuits under voltage are only permitted during installation, for maintenance or repair purposes.

#### Note

The temporal coincidence of explosion hazardous atmosphere and installation, maintenance resp. repair purposes is assessed as improbable.

- For the circuit 'Position feedback with proximity switches or microswitches' measures have to be taken outside the device that the rated voltage is exceeded not more than 40 % by transient disturbances.
- Only non combustible gases are allowed to be used as pneumatic auxiliary energy.
- Only suitable cable entries which meet the requirements of IEC 60079-15 are allowed to be used.

### Use, operation

The TZIDC is only approved for intended and appropriate use. In case of non-compliance, the warranty and manufacturer's liability do no longer apply!

- In explosive atmospheres only such auxiliary components shall be used that meet all requirements of the European and the national standards.
- The ambient conditions specified in the instruction manual have to be adhered to strictly.
- The TZIDC has only been approved for its appropriate and intended use in standard industrial atmospheres. Where aggressive substances are present in the air, the manufacturer has to be consulted.



## Maintenance, repair

**Maintenance:** defines a combination of any actions carried out to retain an item in, or restore it to, conditions in which it is able to meet the requirements of the relevant specification and perform its required functions.

### Inspection:

defines any action comprising careful scrutiny of an item carried out either without dismantling, or with the addition of partial dismantling as required, supplemented by means such as measurement, in order to arrive at reliable conclusion as to the condition of an item.

### Visual inspection:

defines an inspection which identifies, without the use of access equipment and tools, those defects, such as missing bolts, which will be apparent to the eye.

### Close inspection:

defines an inspection which encompasses those aspects covered by a visual inspection and, in addition, identifies those defects, such as loose bolts, which will be apparent only by the use of access equipment, for example steps, where necessary, and tools.

### Detailed inspection:

defines an inspection which encompasses those aspects covered by a close inspection and, in addition, identifies those defects, such as loose terminations, which will only be apparent by opening the enclosure, and/or using, where necessary, tools and test equipment.

- Maintenance or replacement works are to be carried out by qualified personnel only, i.e. personnel qualified according to TRBS 1203 or similar.
- Only such auxiliary components may be used in explosive atmospheres which meet all requirements of European and national directives and legislation.
- Maintenance works that require a dismantling of the system shall only be performed if the atmosphere is Ex-free. If that is not possible, however, the usual precautions have to be ensured according to local regulations.
- Components shall only be replaced by original spare parts which are therefore approved for the use in explosive atmospheres.
- Inside the Ex-atmosphere the equipment has to be cleaned regularly. The intervals are to be defined by the user in compliance with the environmental conditions present at the place of operation.
- After maintenance and repair works have been performed, all barriers and notes removed for that purpose have to be put back in their original place.
- The flameproof joints differ from the tables of IEC 60079-1 and should only be repaired by the manufacturer.

## Activity

Activity	Visual inspection every 3 months	Close inspection every 6 months	Detailed inspection every 12 months
Visual inspection of positioner for intactness, removal of dust settlements	●		
Check of electrical system for intactness and functionality			●
Check of entire system	User's responsibility		

## Fault elimination

No changes or modifications may be performed on equipment that is operated in conjunction with explosive atmospheres. Such equipment shall only be repaired by expert personnel trained and authorized to do so.

---

## ... Use in potentially explosive atmospheres

### ... cFMus

#### Warning markings

- “TO PREVENT IGNITION OF FLAMMABLE GASES OR VAPORS, DO NOT REMOVE COVER WHILE CIRCUITS ARE LIVE”  
“POUR ÉVITER L'INFLAMMATION DE GAZ OU DE VAPEURS INFLAMMABLES, NE PAS RETIRER LE COUVERCLE LORSQUE LES CIRCUITS SONT SOUS TENSION.”
- “FOR PROPER SELECTION OF CABLES SEE ELECTRICAL INSTALLATION INSTRUCTIONS IN THE MANUAL”  
“POUR LA SÉLECTION APPROPRIÉE DES CÂBLES, VOIR LES INSTRUCTIONS D'INSTALLATION ÉLECTRIQUE DANS LE MANUEL”

If the equipment was tested according to the exception of table 5 from FM class 3615, the label shall contain the statement:

- “SEAL ALL CONDUITS WITHIN 18 INCHES”  
“SCELLER TOUS LES CONDUITS À MOINS DE 18 POUCES”

Equipment supplied with a factory-installed conduit seal shall be marked with the words:

- “FACTORY SEALED, CONDUIT SEAL NOT REQUIRED”  
“SCELLÉ EN USINE, JOINT DE CONDUIT NON REQUIS”

## FM installation drawing No. 901265

Page 1 of 5

## FM-CONTROL-DOCUMENT\_901265

1. Entity concept / Ex ec (TZIDC, TZIDC-110/-120)								
	Concept	Groups	Vmax (V)	Imax (mA)	Pmax (W)	Ci (nF)	Li (μH)	Comment
Terminals +11, -12	Entity	IIC / ABCD	30	320	1.1	6.6	-	Analog Input
	FISCO	IIC / ABCD	17.5	183	-			Input
	FISCO	IIB / CD	17.5	380	-			Input
Terminals +31, -32	Entity	IIC / ABCD	30	320	1.1	6.6	-	Analog Position Feedback
Terminals +41, -42; +51, -52	Entity	IIC / ABCD	30	320	0.25	3.7	-	Digital Feedback
Terminals +41, -42; +51, -52	Entity	IIC / ABCD	16	25	0.064	60	100	Limit switches
Terminals +81, -82	Entity	IIC / ABCD	30	320	1.1	14.5	-	Digital Input
Terminals +83, -84	Entity	IIC / ABCD	30	320	0.5	14.5	-	Digital Output

2. Intrinsic safety / Ex I (TZIDC, TZIDC-110/-120)								
	Concept	Groups	Vmax (V)	Imax (mA)	Pmax (W)	Ci (nF)	Li (μH)	Comment
Terminals +11, -12	Intrinsic safe	IIC / IIIC / ABCDEFG	30	320	1.1	6.6	-	Analog Input
	FISCO	IIC / IIIC / ABCDEFG	17.5	183	-			Input
	FISCO	IIB / IIIC / CDEFG	17.5	380	-			Input
Terminals +31, -32	Intrinsic safe	IIC / IIIC / ABCDEFG	30	320	1.1	6.6	-	Analog Position Feedback
Terminals +41, -42; +51, -52	Intrinsic safe	IIC / IIIC / ABCDEFG	30	320	0.25	3.7	-	Digital Position Feedback
Terminals +41, -42; +51, -52	Intrinsic safe	IIC / IIIC / ABCDEFG	16	25	0.064	60	100	Limit switches
Terminals +81, -82	Intrinsic safe	IIC / IIIC / ABCDEFG	30	320	1.1	14.5	-	Digital Input
Terminals +83, -84	Intrinsic safe	IIC / IIIC / ABCDEFG	30	320	0.5	14.5	-	Digital Output

3. Flameproof / Ex d (TZIDC-200/-210/-220)								
	Concept	Groups	Vmax (V)	Imax (mA)	Pmax (W)	Ci (nF)	Li (μH)	Comment
Terminals +11, -12	Flameproof	IIC / ABCDEFG	30					Analog Input
	FISCO	IIC / ABCDEFG	17.5	183				Input
	FISCO	IIB / CDEFG	17.5	380				Input
Terminals -31, -32	Flameproof	IIC / ABCDEFG	30					Analog Position Feedback
Terminals +51, -52; +41, -42	Flameproof	IIC / ABCDEFG	30					Digital Position Feedback
Terminals +51, -52; +41, -42	Flameproof	IIC / ABCDEFG	30					Mechanical Digital Feedback
Terminals +41, -42; +51, -52	Flameproof	IIC / ABCDEFG	16					Limit switches

Ambient temperature TZIDC-200/-210/-220 Temperature class T5 = -40°C to 82°C

8		2022-02-19	Pet.	2003	Date	Name	Title	Scale
7	DIP marking removed	2021-06-23	Ste	Name	27.03.03	Thiem.		
6		2020-04-28	Ste	Appr.			No change without notice to FM	Page -1/-5-
5		2011-07-08	Thie	Std.				
4		2009-10-07	Lasa.	<b>ABB</b> Automation Products				
3		2006-06-26	Thie.					
2		2006-05-22	Thie.				Supersedes Dwg. :	Part Class:
1		2006-03-27	Thie.					
Rev.	Change	Date	Name					

... Use in potentially explosive atmospheres

... cFMus

**FM-CONTROL-DOCUMENT\_901265**

Non-Hazardous Location	HAZARDOUS (CLASSIFIED) LOCATION Class I, II, III Div. I & 2 Group A-G Class I Zone 1, 21 Group IIC or IIB/ IIIC																																													
Any FM/CSA Approved Associated Apparatus	<table border="1" style="width: 100%;"> <tr> <td colspan="2">TZIDC-xxx</td> </tr> <tr> <td>+11</td> <td>Analog Input</td> </tr> <tr> <td>-12</td> <td>Analog Input</td> </tr> <tr> <td>+31</td> <td>Analog Position Feedback / Limit Switches</td> </tr> <tr> <td>-32</td> <td>Analog Position Feedback / Limit Switches</td> </tr> <tr> <td>+41</td> <td>Digital Position Feedback /</td> </tr> <tr> <td>-42</td> <td>Digital Position Feedback</td> </tr> <tr> <td>+51</td> <td>Digital Position Feedback/ Limit Switches</td> </tr> <tr> <td>-52</td> <td>Digital Position Feedback/ Limit Switches</td> </tr> <tr> <td>+81</td> <td>Digital Input</td> </tr> <tr> <td>-82</td> <td>Digital Input</td> </tr> <tr> <td>+83</td> <td>Digital Output</td> </tr> <tr> <td>-84</td> <td>Digital Output</td> </tr> </table> <p style="text-align: right;">→Any FM/ CSA Approved Terminator (maynot be necessary for Entity Installations)</p> <table border="1" style="width: 100%;"> <tr> <td colspan="3"><b>Ambient temperature dependent on temperature class</b></td> </tr> <tr> <td><b>Type and Marking</b></td> <td colspan="2">TZIDC, TZDIC-110/-120</td> </tr> <tr> <td rowspan="2">Ambient temperature</td> <td>Gas atmosphere</td> <td>Dust atmosphere</td> </tr> <tr> <td>Temperature class</td> <td>Ambient temperature</td> </tr> <tr> <td>-40 °C to 85 °C</td> <td>T4</td> <td>T 125°C</td> </tr> <tr> <td>-40 °C to 40 °C</td> <td>T6</td> <td>T 85°C</td> </tr> </table>			TZIDC-xxx		+11	Analog Input	-12	Analog Input	+31	Analog Position Feedback / Limit Switches	-32	Analog Position Feedback / Limit Switches	+41	Digital Position Feedback /	-42	Digital Position Feedback	+51	Digital Position Feedback/ Limit Switches	-52	Digital Position Feedback/ Limit Switches	+81	Digital Input	-82	Digital Input	+83	Digital Output	-84	Digital Output	<b>Ambient temperature dependent on temperature class</b>			<b>Type and Marking</b>	TZIDC, TZDIC-110/-120		Ambient temperature	Gas atmosphere	Dust atmosphere	Temperature class	Ambient temperature	-40 °C to 85 °C	T4	T 125°C	-40 °C to 40 °C	T6	T 85°C
TZIDC-xxx																																														
+11	Analog Input																																													
-12	Analog Input																																													
+31	Analog Position Feedback / Limit Switches																																													
-32	Analog Position Feedback / Limit Switches																																													
+41	Digital Position Feedback /																																													
-42	Digital Position Feedback																																													
+51	Digital Position Feedback/ Limit Switches																																													
-52	Digital Position Feedback/ Limit Switches																																													
+81	Digital Input																																													
-82	Digital Input																																													
+83	Digital Output																																													
-84	Digital Output																																													
<b>Ambient temperature dependent on temperature class</b>																																														
<b>Type and Marking</b>	TZIDC, TZDIC-110/-120																																													
Ambient temperature	Gas atmosphere	Dust atmosphere																																												
	Temperature class	Ambient temperature																																												
-40 °C to 85 °C	T4	T 125°C																																												
-40 °C to 40 °C	T6	T 85°C																																												

8		2022-02-19	Pet.	2003	Date	Name	Title	Scale	
7	DIP marking removed	2021-06-23	Ste	Name	27.03.03	Thiem.			FM-Control-Document
6		2020-04-28	Ste	Appr.			No change without notice to FM	Page -2/5-	
5		2011-07-08	Thie	Std.					<b>ABB</b> Automation Products
4		2009-10-07	Lasa.				Drwg.-No. (Part-No.) <b>901265</b>		
3		2006-06-26	Thie.						
2		2006-05-22	Thie.						
1		2006-03-27	Thie.						
Rev.	Change	Date	Name				Supersedes Dwg. :	Part Class:	

## FM-CONTROL-DOCUMENT\_901265

### FISCO rules

The FISCO Concept allows the interconnection of intrinsically safe apparatus to associated apparatus not specifically examined in such combination.

The criterion for such interconnection is that the voltage ( $V_{max}$ ), the current ( $I_{max}$ ) and the power ( $P_i$ ) which intrinsically safe apparatus can receive and remain intrinsically safe, considering faults, must be equal or greater than the voltage ( $U_o$ ,  $V_{oc}$ ,  $V_t$ ), the current ( $I_o$ ,  $I_{sc}$ ,  $I_t$ ) and the power ( $P_o$ ) which can be provided by the associated apparatus (supply unit).

In addition, the maximum unprotected residual capacitance ( $C_i$ ) and inductance ( $L_i$ ) of each apparatus (other than the terminators) connected to the Fieldbus must be less than or equal to 5 nF and 10  $\mu$ H respectively.

In each I.S. Fieldbus segment only one active source, normally the associated apparatus, is allowed to provide the necessary power for the Fieldbus system.

The allowed voltage ( $U_o$ ,  $V_{oc}$ ,  $V_t$ ) of the associated apparatus used to supply the bus must be limited to the range of 14V d.c. to 24V d.c.

All other equipment connected to the bus cable has to be passive, meaning that the apparatus is not allowed to provide energy to the system, except to a leakage current of 50  $\mu$ A for each connected device.

Separately powered equipment needs a galvanic Isolation to insure that the intrinsically safe Fieldbus circuit remains passive.

The cable used to interconnect the devices needs to comply with the following parameters:

Loop resistance	R': 15...150 $\Omega$ /km
Inductance per unit length	L': 0.4...1mH/km
Capacitance per unit length	C':80...200 nF / km
	C' = C' line/line + 0.5C' line/screen, if both lines are floating or
	C' = C' line/line + C' Line/screen, if the screen is connected to one line
Length of spur cable:	max. 30m
Length of trunk cable:	max. 1km
Length of splice:	max. 1m

### Terminators

At each end of the trunk cable an approved line terminator with the following parameters is suitable:

- R = 90...100  $\Omega$
- C = 0...2.2  $\mu$ F.

### System evaluation

The number of passive devices like transmitters, actuators, connected to a single bus segment is not limited due to I.S. Reasons. Furthermore, if the above rules are respected, the inductance and capacitance of the cable need not to be considered and will not impair the intrinsic safety of the installation.

8		2022-02-19	Pet.	2003	Date	Name	Title <b>FM-Control-Document</b>	Scale  /
7	DIP marking removed	2021-06-23	Ste	Name	27.03.03	Thiem.		
6		2020-04-28	Ste	Appr.				
5		2011-07-08	Thie	Std.				
4		2009-10-07	Lasa.	<b>ABB</b>  Automation Products			No change without notice to FM	
3		2006-06-26	Thie.				Drwg.-No. (Part-No.) <b>901265</b>	Page -3/5-
2		2006-05-22	Thie.					
1		2006-03-27	Thie.					
Rev.	Change	Date	Name				Supersedes Dwg. :	Part Class:

## ... Use in potentially explosive atmospheres

### ... cFMus

Page 4 of 5

## FM-CONTROL-DOCUMENT\_901265

### Installation Notes

#### A. Installation notes for all ignition protection methods

- Control equipment connected to the Associated Apparatus must not use or generate more than 250 Vrms or Vdc.
- Installation should be in accordance with ANSI/ISA RP12.6 (except chapter 5 for FISCO Installations) "Installation of Intrinsically Safe System for Hazardous (Classified) Locations" and the National Electrical Code® (ANSI/NFPA 70) Sections 504 and 505.
- Output current must be limited by a resistor such that the output voltage current plot is a straight line drawn between open circuit voltage and short circuit current
- The operation of the local communication interface (LKS) and of the programming interface (X5) is only allowed outside of the Hazardous explosive area.
- Tampering and replacement with non-factory components may adversely affect the safe use of the system. Substitution of components may impair suitability for hazardous locations.
- For FM Div. 2 use: Do not connect or disconnect unless the power was switched off or the area is known to be non hazardous
- Preventing electrostatic charging
- Due to the possibility of impermissible electrostatic charging of the housing occurring, the effects of high-voltage sources on the equipment must be prevented. Electrostatic charging can also occur if the device is wiped with a dry cloth or if large amounts of dust flow around the device in dusty environments.
- To prevent charging of this type from occurring, the C, device may only be cleaned using a damp cloth.
- Dust flowing round the device should be prevented by installing a flow restrictor or partition.

#### B. Installation Notes for I.S.

- The Intrinsic Safety Entity concept allows the interconnection of FM/CSA Approved Intrinsically safe devices with entity parameters not specifically examined in combination as a system when:
  - $U_o$  or  $V_{OC}$  or  $V_t \leq V_{max}$ ,  $I_o$  or  $I_{sc}$  or  $I_t \leq I_{max}$ ,  $P_o \leq P_i$ .  $C_a$  or  $C_o \geq \sum C_i + \sum C_{cable}$ .
  - For inductance use either  $L_a$  or  $L_o \geq \sum L_i + \sum L_{cable}$  or  $L_c / R_c \leq (L_a / R_a$  or  $L_o / R_o)$  and  $L_i / R_i \leq (L_a / R_a$  or  $L_o / R_o)$
- The Intrinsic Safety FISCO concept allows the interconnecting of FM/CSA Approved Intrinsically safe devices with FISCO parameters not specifically examine in combination as a system when:  $U_o$  or  $V_{OC}$  or  $V_t \leq V_{max}$ ,  $I_o$  or  $I_{sc}$  or  $I_t \leq I_{max}$ ,  $P_o \leq P_i$ .
- The configuration of associated Apparatus must be Factory Mutual Research /Canadian Standards Association Approved under the associated concept.
- Associated Apparatus manufacturer's installation drawing must be followed when installing this equipment.
- Caution: Substitution of components may impair intrinsic safety.
- To maintain intrinsic safety, wiring associated with each channel must be run in separate cable shields connected to intrinsically safe (associated apparatus) ground.

8		2022-02-19	Pet.	2003	Date	Name	Title	Scale
7	DIP marking removed	2021-06-23	Ste	Name	27.03.03	Thiem.		
6		2020-04-28	Ste	Appr.			No change without notice to FM	
5		2011-07-08	Thie	Std.				
4		2009-10-07	Lasa.	<b>ABB</b> Automation Products				
3		2006-06-26	Thie.					
2		2006-05-22	Thie.					
1		2006-03-27	Thie.					
Rev.	Change	Date	Name				Supersedes Dwg. :	Part Class:

**FM-CONTROL-DOCUMENT\_901265****C. Installation notes for flameproof housing**

17. Dust-tight conduit seal must be used when installed in Class II and Class III environments.
18. When connecting conduit to the enclosure use conduit hubs that have the same environmental rating as the enclosure

**D. NONINCENDIVE, CLASS I, DIV. 2, GROUP A, B, C, D, AND FOR CLASS II AND III, DIV. 1&2, GROUP E, F, G HAZARDOUS LOCATION INSTALLATION**

1. Install per National Electrical Code (NEC) using threaded metal conduit. Intrinsic safety barrier required. Max. Supply voltage 30 V. For T-code see table.
2. A dust tight seal must be used at the conduit entry when the positioner is used in a Class II & III Location.
3. **WARNING:** Explosion Hazard – do not disconnect equipment unless power has been switched off or the area is known to be Non-Hazardous.  
**WARNING:** Substitution of components may impair suitability for hazardous locations.

FM-901265 FM-Control-Documnet Rev.8

8		2022-02-19	Pet.	2003	Date	Name	Title	Scale
7	DIP marking removed	2021-06-23	Ste	Name	27.03.03	Thiem.	FM-Control-Documnet	/
6		2020-04-28	Ste	Appr.			No change without notice to FM	
5		2011-07-08	Thie	Std.				
4		2009-10-07	Lasa.	<b>ABB</b> Automation Products			Drwg.-No. (Part-No.)	Page -5/-5-
3		2006-06-26	Thie.				<b>901265</b>	
2		2006-05-22	Thie.					
1		2006-03-27	Thie.					
Rev.	Change	Date	Name				Supersedes Dwg. :	Part Class:

## ... Use in potentially explosive atmospheres

### EAC TR-CU-012

#### Ex marking

Ex marking	
Marking	1Ex ia IIC T6/T4 Gb X 1Ex ib IIC T6/T4 Gb X
Certificate	EAC TR-CU-012
Type	Intrinsically safe equipment
Standards	EN 60079-0, EN 60079-11

#### Special conditions

- The power supply for the 'Feedback on the actuator position using proximity switches (Pepperl & Fuchs SJ2-SN)' circuit must be provided intrinsically safe in accordance with the PTB 00 ATEX 2049 X / RU C-DE.AA87.B.00394 certificate according to application type 2.
- It is only permissible to connect, disconnect, and switch live circuits during installation or maintenance, or for the purpose of carrying out repairs.

#### Note

It is considered very unlikely that a potentially hazardous atmosphere would be present in Zone 2 at the same time that installation or maintenance or repair work was being carried out.

- Only non-flammable gases must be used for pneumatic power supply.
- Only use suited cable entries that meet the requirements of EN 60079-11.

#### Temperature characteristic curves

Intrinsically safe circuit according to ATEX and EAC / TR CU 012/2011

- Equipment Category 1: Use in Zone 0
- Equipment Category 2: Use in Zone 1
- Equipment Category 3: Use in Zone 2

#### Temperature Data

Temperature class	Ambient temperature $T_a$
T4	-40 to +85 °C
T6*	-40 to 40 °C*

\* When using the 'Plug-in module for digital feedback' in temperature class T6, the maximum permissible ambient temperature range is -40 to +35 °C.

#### Electrical Data

In type of protection 'Intrinsic safety Ex ia, Ex ib', only for connection to a certified intrinsically safe circuit.

Current circuit (terminal)	Electrical information (maximum values)	
Signal circuit (+11 / -12)	$U_i = 30 \text{ V}$ $I_i = 320 \text{ mA}$ $P_i = 1.1 \text{ W}$	$C_i = 6.6 \text{ nF}$ $L_i = \text{negligibly small}$
Contact input (+81 / -82)	$U_i = 30 \text{ V}$ $I_i = 320 \text{ mA}$ $P_i = 1.1 \text{ W}$	$C_i = 14.5 \text{ nF}$ $L_i = \text{negligibly small}$
Switch output (+83 / -84)	$U_i = 30 \text{ V}$ $I_i = 320 \text{ mA}$ $P_i = 500 \text{ mW}$	$C_i = 14.5 \text{ nF}$ $L_i = \text{negligibly small}$
Feedback on the actuator position using proximity switches, (Pepperl & Fuchs SJ2-SN) (Limit1: +51 / -52), (Limit2: +41 / -42)	For maximum values, see EU-Type examination certificate PTB 00 ATEX 2049 X / RU C-DE.AA87.B.00394 Pepperl & Fuchs Type 2 proximity switches	
Plug-in module for digital feedback (+51 / -52) (+41 / -42)	$U_i = 30 \text{ V}$ $I_i = 320 \text{ mA}$ $P_i = 250 \text{ mW}$	$C_i = 3.7 \text{ nF}$ $L_i = \text{negligibly small}$
Plug-in module for analog feedback (+31 / -32)	$U_i = 30 \text{ V}$ $I_i = 320 \text{ mA}$ $P_i = 1.1 \text{ W}$	$C_i = 6.6 \text{ nF}$ $L_i = \text{negligibly small}$
Interface with the TZIDC Remote Sensor (X2-2: +Uref, X3-2: GND, X3-1: Signal)	$U_0 = 5.4 \text{ V}$ $I_0 = 74 \text{ mA}$ $P_0 = 100 \text{ mW}$ $C_i = \text{negligibly small}$ $L_i = \text{negligibly small}$	Ex ia or Ex ib type of protection IIC: $L_0 = 5 \text{ mH}$ $C_0 = 2 \mu\text{F}$ IIB: $L_0 = 5 \text{ mH}$ $C_0 = 10 \mu\text{F}$
Local communication interface (LCI)	Only for connection to a programming device using an ABB LCI adapter ( $U_m \leq 30 \text{ V DC}$ ) outside the hazardous area.	



## Ordering Information

### Main ordering information TZIDC

Base model	V18345	XX	X	X	X	X	X	XX	X
TZIDC digital positioner, intelligent, configurable, with indicator and operator panel									
<b>Case / Mounting</b>									
Case made of aluminium, varnished, for mounting to linear actuators acc. DIN / IEC 534 / NAMUR or to rotary actuators acc. VDI / VDE 3845									10
Case made of aluminium, varnished, with mechanical position indicator, for mounting to linear actuators acc. DIN / IEC 534 / NAMUR or to rotary actuators acc. VDI / VDE 3845									20
Case made of aluminium, varnished, for integral mounting to control valves (see dimensional drawing)									30
Case made of aluminium, varnished, with mechanical position indicator, for integral mounting to control valves (see dimensional drawing)									40
Remote sensor control unit									70*
<b>Input / Communication Port</b>									
Input 4 to 20 mA, two-wire, with connector plug for LCI adapter									1
Input 4 to 20 mA, two-wire, with connector plug for LCI adapter and FSK module for HART communication									2
<b>Explosion Protection</b>									
Without									0
ATEX II 2 G Ex ib IIC T6 resp. T4 Gb									1
cFMus									2
IECEX Ex ib IIC T6 resp. T4 Gb									5
ATEX II 2 G Ex ia IIC T6 resp. T4 Gb									7
UKEX Ex ia									A
UKEX Ex ib									B
EAC 1Ex ia IIC T6/T4 Gb X									H**
EAC 1Ex ib IIC T6/T4 Gb X									J**
IECEX ia IIC T6 resp. T4 Gb									K
NEPSI Ex ia IIC T4/T6 Gb									U
NEPSI Ex ib IIC T4/T6 Gb									V
INMETRO Ex ib IIC Gb T4/T6 Gb									P
KOSHA Ex ib									R
<b>Output / Safe Position (in case of an electrical power failure)</b>									
Single acting, fail safe									1
Single acting, fail freeze									2
Double acting, fail safe									4***
Double acting, fail freeze									5***

\* With standard characteristic curve, if delivered without remote sensor

\*\* Reduced Functionality

\*\*\* Not for for integral mounting

Continued see next page

## ... Ordering Information

### ... Main ordering information TZIDC

<b>TZIDC digital positioner, intelligent, configurable, with indicator and operator panel</b>	<b>X</b>	<b>X</b>	<b>XX</b>	<b>X</b>
<b>Connections</b>				
Cable: Thread ½-14 NPT, air pipe: Thread ¼-18 NPT	2			
Cable: Thread M20 × 1.5, air pipe: Thread ¼-18 NPT	5			
Cable: Thread M20 × 1.5, air pipe: Thread G ¼	6			
Cable: Thread G ½, air pipe: Thread Rc ¼	7			
<b>Option Modules for Analog or Digital Position Feedback</b>				
Without		0		
Plug-in module for analog position feedback, signal range 4 bis 20 mA, two-wire		1		
Plug-in module for digital position feedback		3		
Plug-in module for analog position feedback, signal range 4 bis 20 mA, two-wire, and digital position feedback		5		
<b>Optional Mechanical Kit for Digital Position Feedback</b>				
Without			00	
Mechanical kit for digital position feedback with proximity switches SJ2-SN (NC or logical 1)			10*	
Mechanical kit for digital position feedback with 24 V AC / DC microswitches (change-over contacts)			50**	
<b>Design (Varnish / Coding)</b>				
Standard				1
Higher Stiffness + Lower Air Capacity				H***
Protection Class IP 66 / NEMA 4X				P
Increased Corrosion Protection				S

\* Only for model with mechanical position indicator, no IECEx

\*\* Not for explosion protected version and only for model with mechanical position indicator

\*\*\* Only with Type Double Acting

Continued see next page

## Additional ordering information TZIDC

Additional ordering information	XX	XXX	XXX	XXX	XXX	XXX
<b>Documentation Language</b>						
German	M1					
Italian	M2					
Spanish	M3					
French	M4					
English	M5					
Swedish	M7					
Finnish	M8					
Polish	M9					
Portuguese	MA					
Russian	MB					
Czech	MC					
Dutch	MD					
Danish	MF					
Greek	MG					
Croatian	MH					
Latvian	ML					
Hungarian	MM					
Estonian	MO					
Bulgarian	MP					
Romanian	MR					
Slovak	MS					
Lithuanian	MU					
Slovenian	MV					
<b>SIL2 - Declaration of Conformity</b>						
SIL2 - Declaration of Conformity		CS2*				
<b>Certificate of Compliance</b>						
Certificate of compliance with the order acc. EN 10204-2.1 (DIN 50049-2.1) with item description			CF2			
Test report 2.2 acc. EN 10204 (DIN 50049-2.2)			CF3			
<b>Marine approval</b>						
Marine approval DNV_GL				CM1		
<b>CCC Certification</b>						
3CC for Ex i & CCC for Ex d						CCC
<b>UKCA Certification</b>						
UKCA						CU1

\* With single acting, fail safe pneumatic only

## ... Ordering Information

### ... Additional ordering information TZIDC

Additional ordering information	XXX	XXX	XXX	XXX	XXX	XX	XX	XX	XX	XX
<b>Inspection Certificate</b>										
Inspection certificate 3.1 acc. EN 10204	CBA									
<b>Handling of Certificates</b>										
Send via e-mail		GHE								
Send via mail		GHP								
Send via mail express		GHD								
Send with instrument		GHA								
Only archived		GHS								
<b>Certificate preparation</b>										
Per device					GPD					
Per salesorder item					GPP					
<b>Device Identification Label</b>										
Stainless steel 18.5 × 65 mm (0.73 × 2.56 in)					MK1*					
Sticker 11 × 25 mm (0.43 × 0.98 in)					MK3					
<b>Special Option Cable Gland</b>										
With cable gland					ZG1					
<b>Type of position sensor</b>										
Non-contact sensor						S1				
<b>Remote Sensor</b>										
Basic unit									RS**	
Basic unit with position indicator									RD**	
<b>Remote Sensor Temperature Range</b>										
Extended ambient temperature range -40 to 100 °C (-40 to 212 °F)									RT**	
<b>Remote Sensor Vibration Resistance</b>										
Advanced vibration range 2 g @ 300 Hz										RV**
<b>Remote Sensor Protection Class</b>										
Protection class IP 67										RP**
<b>Remote Sensor Cable</b>										
5 m cable enclosed										R5**
10 m cable enclosed										R6**

\* Plain text, max. 16 letters

\*\* Only with remote sensor control unit

## Accessories

Designation	Order no.
<b>Communication</b>	
LCI adapter with USB interface – only for TZIDC HW. Rev. 5	3KXE000128U0100
<b>Mounting bracket</b>	
EDP300/TZIDC attachment bracket for 90° rotary actuators, mounted in accordance with VDI/VDE 3845, bracket dimensions A/B 80/20 mm (aluminum housing)	319603
EDP300/TZIDC attachment bracket for 90° rotary actuators, mounted in accordance with VDI/VDE 3845, bracket dimensions A/B 80/30 mm (aluminum housing)	319604
EDP300/TZIDC attachment bracket for 90° rotary actuators, mounted in accordance with VDI/VDE 3845, bracket dimensions A/B 130/30 mm (aluminum housing)	319605
EDP300/TZIDC attachment bracket for 90° rotary actuators, mounted in accordance with VDI/VDE 3845, bracket dimensions A/B 130/50 mm (aluminum housing)	319606
<b>Attachment kit</b>	
EDP300/TZIDC attachment kit Uhde Type 4 stroke 400 mm cranked	7959500
<b>Mounting kit for linear actuators</b>	
EDP300/TZIDC attachment kit for linear actuators, stroke adjustment 10 to 35 mm	7959125
EDP300/TZIDC attachment kit for linear actuators, stroke adjustment 20 to 100 mm	7959126
<b>Lever</b>	
EDP300/TZIDC lever 30 mm	7959151
EDP300/TZIDC lever 100 mm	7959152
<b>Adapter</b>	
EDP300/TZIDC adapter (axle connector) for part-turn actuators to VDI/VDE 3845	7959110
EDP300/TZIDC keyed shaft adapter	7959371
<b>Pressure gauge block</b>	
TZIDC pressure gauge block, single acting, graphite black, 2 pressure gauges 28 mm, piping connections G ¼ in, 1 x 0 to 10 bar/0 to 140 psi for supply air pressure, 1 x 0 to 10 bar/0 to 140 psi for output pressure, including attachment material	7959112
TZIDC pressure gauge block, 0.6 MPa, single acting, G ¼ in thread	7959364
TZIDC pressure gauge block, 0.6 MPa, single acting, Rc ¼ in thread	7959358
TZIDC pressure gauge block, 0.6 MPa, single acting, ¼ in NPT thread	7959360
TZIDC pressure gauge block, single acting, graphite black, 2 pressure gauges 28 mm, piping connections ¼ in NPT, 1 x 0 to 10 bar/0 to 140 psi for supply air pressure, 1 x 0 to 10 bar/0 to 140 psi for output pressure, including attachment material	7959114
TZIDC pressure gauge block, double acting, graphite black, 3 pressure gauges 28 mm, piping connections G ¼ in, 1 x 0 to 10 bar/0 to 145 psi for supply air pressure, 2 x 0 to 10 bar/0 to 145 psi for output pressure, including attachment material	7959116
TZIDC pressure gauge block, 0.6 MPa, double acting, G ¼ in thread	7959365
TZIDC pressure gauge block, 0.6 MPa, double acting, Rc ¼ in thread	7959359
TZIDC pressure gauge block, 0.6 MPa, double acting, ¼ in NPT thread	7959361
TZIDC pressure gauge block, double acting, graphite black, 3 pressure gauges 28 mm, piping connections ¼ in NPT, 1 x 0 to 10 bar/0 to 140 psi for supply air pressure, 2 x 0 to 10 bar/0 to 140 psi for output pressure, including attachment material	7959118
TZIDC pressure gauge block, double acting, black, 3 pressure gauges VA 28 mm, piping connections ¼ in NPT, 1 x 0 to 10 bar/0 to 140 psi for supply air pressure, 2 x 0 to 10 bar/0 to 140 psi for output pressure, including attachment material	7959185
TZIDC brass filter regulator, connections thread G ¼, including attachment material to the pressure gauge block	7959119
TZIDC brass filter regulator, connections thread ¼-18 NPT, including attachment material to the pressure gauge block	7959120
TZIDC pressure gauge block, black, 2 pressure gauges VA 28 mm, piping connections G ¼ in, 1 x 0 to 10 bar/0 to 140 psi for supply air pressure, 1 x 0 to 10 bar/0 to 140 psi for output pressure, including attachment material	7959179
TZIDC pressure gauge block, double acting, black, 2 pressure gauges VA 28 mm, piping connections G ¼ in, 1 x 0 to 10 bar/0 to 140 psi for supply air pressure, 2 x 0 to 10 bar/0 to 140 psi for output pressure, including attachment material	7959183

## ... Ordering Information

### ... Accessories

Designation	Order no.
<b>Cable glands/screw plugs</b>	
TEIP11-PS/EDP300/TZIDC cable gland NPT1/2" plastic, non-Ex (available Q2-Q3 2023)	3KXE001070U0100
TEIP11-PS/EDP300/TZIDC cable gland M20x1.5 plastic, non-Ex (available Q2-Q3 2023)	3KXE001071U0100
TEIP11-PS/EDP300/TZIDC cable gland M20x1.5 EMC, brass, nickel-plated for Ex eb IIC Gb, Ex ta IIIC Da, Ex i (IP 68) ambient temperature -20 °C to 95 °C (available Q2-Q3 2023)	3KXE001072U0100
TEIP11-PS/EDP300/TZIDC cable gland NPT1/2" EMC, brass, nickel-plated for Ex eb IIC Gb, Ex ta IIIC Da, Ex i (IP 68) ambient temperature -20 °C to 95 °C (available Q2-Q3 2023)	3KXE001073U0100
TEIP11-PS/EDP300/TZIDC cable gland M20x1.5 INOX, stainless steel for Ex db IIC Gb, Ex ta IIIC Da, Ex i (IP 68) ambient temperature -60 °C to 105 °C (available Q2-Q3 2023)	3KXE001074U0100
TEIP11-PS/EDP300/TZIDC cable gland NPT1/2" INOX, stainless steel for Ex db IIC Gb, Ex ta IIIC Da, Ex i (IP 68) ambient temperature -60 °C to 105 °C (available Q2-Q3 2023)	3KXE001075U0100
TEIP11-PS/EDP300/TZIDC cable gland PG11, brass, nickel-plated for Ex eb IIC Gb, Ex ta IIIC Da, Ex i (IP 68) ambient temperature -60 °C to 95 °C (available Q2-Q3 2023)	3KXE001076U0100
TEIP11-PS/EDP300/TZIDC screw plug M20x1.5 black plastic for Ex eb IIC Gb, Ex tb IIIC Db, Ex i (IP 66) ambient temperature -55 °C to 95 °C (available Q2-Q3 2023)	3KXE001077U0100
TEIP11-PS/EDP300/TZIDC screw plug M20x1.5 INOX, stainless steel for Ex db eb IIC Gb, Ex ta IIIC Da, Ex i (IP 68) ambient temperature -60 °C to 180 °C (available Q2-Q3 2023)	3KXE001078U0100
<b>Mounting kit</b>	
EDP300/TZIDC mounting kit for Fisher 1051-30, 1052-30	7959214
EDP300/TZIDC mounting kit for Fisher 1061 Size 130	7959206
EDP300/TZIDC mounting kit for Fisher 471	7959195
EDP300/TZIDC attachment kit for Fisher 657/667 Size 10 ... 90 mm	7959177
EDP300/TZIDC mounting kit for Fisher Gulde 32/34	7959344
EDP300/TZIDC mounting kit for Gulde DK	7959161
EDP300/TZIDC attachment kit for Keystone 79U/E-002(S) ... 79U/E-181(S)	7959147
EDP300/TZIDC mounting kit for Masoneilan CAMFLEX II, VARIMAX, MINITORK II	7959144
EDP300/TZIDC mounting kit for Masoneilan VariPak 28000 Series	7959163
EDP300/TZIDC mounting kit for MaxFlo MaxFlo	7959140
EDP300/TZIDC mounting kit for NAF 791290	7959207
EDP300/TZIDC attachment kit for NAMUR stroke 100 to 170 mm	7959339
EDP300/TZIDC mounting kit for NELES BC6-20, B1C6-20, B18-20, B1J8-20	7959146
EDP300/TZIDC attachment kit, lever for linear actuators, length 150 to 250 mm	7959210
TZIDC attachment kit, for Nuovo Pignone valves, pressure gauge block with 2 pressure gauges, material stainless steel, single acting ¼ in NPT, 0 to 10 bar	7959181
EDP300/TZIDC mounting kit for Samson 241, 271, 3271	7959145
EDP300/TZIDC mounting kit for Samson 3277	7959136
EDP300/TZIDC mounting kit for Schubert&Salzer GS 8020/8021/8023	7959200
EDP300/TZIDC attachment kit for SED stroke 100 mm	7959141
EDP300/TZIDC attachment kit to control device for remote position sensor (for wall and pipe mounting)	7959381
TZIDC attachment kit TZIDC-200 lever 30 mm	7959262
TZIDC accessory Kent Introl 170 mm	7959376
TZIDC accessory Kent Introl 250 mm	7959377



## Trademarks

HART is a registered trademark of FieldComm Group, Austin, Texas, USA

Sales



Service



---

## **ABB Measurement & Analytics**

For your local ABB contact, visit:

**[www.abb.com/contacts](http://www.abb.com/contacts)**

For more product information, visit:

**[www.abb.com/positioners](http://www.abb.com/positioners)**

---

We reserve the right to make technical changes or modify the contents of this document without prior notice. With regard to purchase orders, the agreed particulars shall prevail. ABB does not accept any responsibility whatsoever for potential errors or possible lack of information in this document.

We reserve all rights in this document and in the subject matter and illustrations contained therein. Any reproduction, disclosure to third parties or utilization of its contents – in whole or in parts – is forbidden without prior written consent of ABB.